

## **Booth Construction and Red Tag - FAQ's - 2016**

To help get your booth ready for the Fair, your Red Tag Crew has put together this handout to give you the highlights of who, what, and how. You can find more in-depth construction information by either going to the website at: [www.oregoncountryfair.net](http://www.oregoncountryfair.net) or in your Guidelines booklet.

Please understand that current building practices have changed and evolved since the manual was last updated. It still can be used as a good general reference. Some of the manual changes include: no digging of posts into the ground, sizes of posts, joists, plywood, brace ideas, signs, aesthetics, paint, and sealant rules. The Red Tag Crew will work with you to help you understand these and other changes.

### **WHO IS THE RED TAG CREW?**

A small group of the Construction Crew who arrives early to shake and rattle each booth to help find the problems that need fixing. Booths that need repair are given a red tag and a courtesy call to notify the booth rep of needed repairs. We are available to offer ideas and solutions to help your particular situation. We concentrate on structural safety but also raise concerns regarding design aesthetics, environmental sensitivity, and archaeological preservation. We can be found at the Construction Booth in Main Camp.

### **TAGS**

#### **What is a yellow tag?**

A yellow tag is used to notify you of the annual loft safety check. Once your removable loft items (such as: fastened ladders & railings) are installed, please contact the Red Tag Crew for final inspection. Our loft inspection may reveal other needed repairs.

#### **What is a red tag?**

A red tag is used to notify you of significant structural items to be repaired, replaced, and/or changed in your booth.

### **THE MAJOR DO'S AND DON'TS**

Do check in with Construction and Quarter Master in Main Camp before any repairs or construction improvements begin.

Do contact Vegemanics at Main Camp about all tree and plant adjustments.

Do bring a fire extinguisher and a basic tool kit.

Do get in the habit of doing your own safety checks to your booth.

Do ask Greeters to facilitate your material deliveries to your booth. Note: Weather may dictate site accessibility.

Do ensure that all designs and construction address seasonal flooding. Structures must be built with removable walls, floors, and skirt elements to let the sun and rain through.

Do put wood to be recycled along the trail side for removal by Site Crew.

Do not use pressure treated wood or unapproved wood preservatives.

Do not dig without Archeology approval.

Do not do any construction work before Main Camp opens on June 4, 2016.

Do not remove red tags! The Red Tag crew will remove this posting when you pass inspection.

Overwhelmed? Please talk to us. We have lots of tips and tricks to offer.

### **SETUP AND REPAIRS**

#### **When do I have to check in?**

Check in if you have a red tag, yellow tag, new construction projects, or for structural alterations. You do not have to check in with Construction if you are just setting up your sales display.

When in doubt, please ask your Red Tag Crew @ the Construction desk @ Main Camp.

### **When do I need a 'permit' ?**

OCF manages all OCF booth permits. OCF permits are required for ANY structural alterations, additions, and/or new construction.

OCF permits are not required for most Red Tag repairs and non-structural repairs such as shelves, counters and display items.

### **Do I need to apply to Lane County for a permit?**

NO. Please bring your booth plans to the Construction Booth at Main Camp. All OCF booth permits and plan approvals are given by the Red Tag Crew.

### **When do I need drawings?**

Drawings are required for new construction or major repairs.

OCF permit forms and examples of various booth plans are available in the on line Booth Construction Manual. Simple plans and sketches are acceptable with a cover letter.

### **Where do I submit my 'permit', plans, sketches?**

They can be sent directly to the OCF office or to a Red Tag Crew member listed below.

Please put your booth number on your communications.

## **FOOD BOOTHS**

There are additional concerns regarding food booths such as: water towers, gray drains, removable floors, flammable materials, and more. It is imperative that food booths check in with us regularly and often. We do have lots of tricks to solve such issues, so please let us help.

## **WINTER STORAGE**

### **What do I do to help my booth survive the winter after the Fair?**

For over a decade we have been working on evolving our booths to have more removable parts (that can be stored in the booth) to promote better flood and rain drainage and to let light flow through. Many of you have heard us say "bones (structure) are good, skins (walls, floors, roofs) are bad." With some creative thinking it is easy to make parts of your booth removable which are then stood up, roped in, and 'stored' for winter. Over the years a lot of good has come with this method. Bones can dry out between rains. We can get to the bones to inspect them. Floors and such last longer stored on their sides. If you can come to the site in spring you will see amazing flowers growing in your booth, where before they could not because of the shade from your loft floor. Please help us continue with creative designs and tidy storage efforts before you leave the site for the season.

Please note recent updates for off season storage requirements in the Guidelines.

## **CONCLUSIONS**

We encourage creativity and individuality with construction planning and design. There are so many talented people at our Fair that have invented new details and tricks on how to build the most amazing booth structures. Our pockets are full of ideas harvested from so many of you over the years. We do have standards and goals to meet and we want to make this a positive experience for everyone.

## **Your Red Tag Crew:**

David Tipton - construction co-co [onthebus1@msn.com](mailto:onthebus1@msn.com)

Kirk Shultz - construction co-co [haviland13@comcast.net](mailto:haviland13@comcast.net)

Tony and Jan Royalty - construction staff

Trevor Shultz -construction staff

Brandt Weaver – construction staff



**Oregon Country Fair  
Booth Repair and Maintenance Manual**

.....  
**TABLE OF CONTENTS**

**INTRODUCTION..... 4**

**INTRODUCTION..... 4**

    THE 2002 REVISED BOOTH CONSTRUCTION & MAINTENANCE MANUAL..... 4

    WHERE ARE WE IN THIS PROCESS : ..... 4

    THE LAND USE MANAGEMENT PLAN (LUMP)..... 6

    THE BASIC IDEA..... 6

*Non-conforming structures* ..... 7

    THE PROCESS BEGINS WITH INSPECTIONS ..... 7

*Notification of Defects*..... 7

*Formal Notice of Booth Holder Liability and OCF Non-Liability*..... 8

**CONSTRUCTION PERMITS..... 8**

    GOALS OF THE OCF PERMIT PROCESS: ..... 8

    IMPLEMENTATION OF OCF GOALS THROUGH THE PERMIT PROCESS ..... 9

*How do I know if I need a permit?*..... 9

*Permit Triggers*..... 9

*How do I know if I need OCF Plan Review?*..... 10

    THE OCF PERMIT PROCESS ..... 11

    OUTLINE OF THE PERMITTING PROCESS ..... 12

    THE “RED TAG” PROCESS ..... 13

    NEW CONSTRUCTION (OR MAJOR REBUILD)..... 14

    GETTING THE WORK DONE: ..... 14

*Procedure:* ..... 14

    AFTER THE FAIR/YEARLY MAINTENANCE ..... 15

*Required Post-Fair booth "close up" activities*..... 15

*Suggested additional Post Fair booth "close up" activities*..... 16

**DESIGN GUIDELINES ..... 16**

    MEETING LUMP REQUIREMENTS FOR TEMPORARY STRUCTURES ..... 16

*The Fully Portable Booth: bones, skins and portability*..... 17

    GENERAL DESIGN GUIDELINES (APPLY TO ALL CONSTRUCTION): ..... 17

*Aesthetics:*..... 18

*Portability:*..... 18

*Alter-abled Access*..... 18

*Booth Setback Guidelines (per LUMP):*..... 18

*Footprint/Traffic Flow:*..... 19

    BASIC DESIGN STANDARDS (APPLY TO ALL BOOTH STRUCTURES ) ..... 19

*Vegetation Management* ..... 19

*Storage Lofts*..... 19

*Water Barrel support* ..... 19

*Exposed Fasteners*..... 20

    SPECIFIC GUIDELINES FOR BOOTH COMPONENTS ..... 20

*Structures that might break loose and float away* ..... 20

*Roofs*..... 20

.....

<i>Lofts</i> .....	21
<i>Floors</i> .....	23
<i>Walls</i> .....	24
<i>Counters and Counter Skirts</i> .....	25
<i>Engineering Definitely Required</i> .....	28
CALL BEFORE YOU DIG.....	29
REDUCE WASTE OF MATERIALS .....	29
<b>CONSTRUCTION DETAILS .....</b>	<b>31</b>
DETAILS OF BOOTH CONSTRUCTION .....	32
<i>Storage racks for Water Barrels and Dry Wells</i> .....	32
<i>Storage loft-size and load assumptions</i> .....	32
<i>Post and Pole sizes for storage lofts</i> .....	32
<i>Procedure to determine size and number of support posts</i> .....	33
<i>Structural Requirements for all posts and poles:</i> .....	33
<i>Repairs to "grandfathered" storage lofts</i> .....	34
<i>Diagonal braces (short ones are also referred to as "knee braces")</i> .....	34
<i>Ground level floors</i> .....	35
<i>Ground Clearance</i> .....	35
STORAGE LOFT FLOOR FRAMING .....	36
<i>Floor Joists</i> .....	38
JOIST CALCULATIONS .....	39
<i>Span/depth calculation for beams</i> .....	40
<i>Floor boards</i> .....	40
<i>Panel Span calculations</i> .....	41
SPECIAL REQUIREMENTS FOR STORAGE LOFTS, LADDERS AND STAIRS.....	41
<i>Safety considerations for storage lofts</i> .....	42
<i>Freestanding Lofts</i> .....	43
BOOTH REPAIRS .....	43
<i>Post Repairs</i> .....	43
<i>Repairs to storage loft floors</i> .....	45
<i>Repairs to beams or floor joists</i> .....	46
<b>OCF CONSTRUCTION PERMIT APPLICATION .....</b>	<b>48</b>
REQUIRED INFORMATION.....	50
<i>Additional details that must be included in drawings or notes are:</i> .....	50
<i>Framing Plans MUST show:</i> .....	50
<b>AFTER THE FAIR BOOTH MAINTENANCE CHECKLIST.....</b>	<b>51</b>
ALL REQUIRED POST-FAIR BOOTH ACTIVITIES HAVE BEEN PERFORMED :.....	51
THESE RECOMMENDED POST FAIR ACTIVITIES HAVE BEEN PERFORMED: .....	51
<b>AFTERWORDS.....</b>	<b>52</b>
YOUR COMMENTS AND SUGGESTIONS ARE NEEDED .....	52
SPECIAL THANKS .....	52

.....

**Table of Equations**

Equation 1 Span Depth Calculation..... 40

**Table of Figures**

Figure 1 OCF Plan Review - is it required?..... 10

Figure 2 OCF permit process – Overall Permit and Plan Review flowchart ..... 12

Figure 3 The OCF permit process - Red Tag flowchart ..... 13

Figure 4 Schematic drawing of a pole-constructed temporary booth 2002 ..... 17

Figure 5 Temporary booth schematic with Integrated counters removable walls, and  
stretcher-bars..... 27

Figure 6 Temporary Loft Booth - framing diagram ..... 28

Figure 8 Sample Drawings - Framing plan and elevations for temporary removable loft  
booth ..... 31

Figure 9 “Knee Brace” framing detail. Show us this much detail in your drawings..... 34

Figure 11 Example construction drawings showing three possible options for storage loft  
framing ..... 37

Figure 13 1 Post repairs - Drawing examples ..... 45

Figure 14 Example of typical drawings required for a post repair ..... 45

**Table of Tables**

Table 1 OCF Construction Permit Triggers..... 10

Table 2 Pole size / post equivalency Chart..... 33

Table 3 Beam and Header Joist Span Table ..... 39

Table 4 Floor Joist Span-table for“Standard or Better” Douglas Fir material ..... 40

Table 5 Panel Span Calculations for plywood loft decking ..... 41

.....

.....

## Introduction

The document that follows is “technical” in nature and as a result, some words are used in particular and limited ways. These words are sometimes called “terms of art.” Terms of art used in this manual are listed at the beginning, so that you will recognize them immediately.

The Oregon Country Fair is a three-day event that takes place near Veneta, Oregon every July. In this document the three-day event we all call “the Fair” is referred to as “the event.”

The Oregon Country Fair is the non-profit (501-C3) Corporation that owns and manages the site on which the event takes place. In this document this organization is referred to as either the “Oregon Country Fair”, “OCF” or “The Fair.” The Construction Crew is an operational unit of the Oregon Country Fair.

The site on which the event takes place is generally referred to as “the site.”

### *The 2002 revised Booth Construction & Maintenance Manual*

You are holding a revised construction manual that reflects a number of years of evolution and provides a roadmap for The Fair's transition from the original “permanent ” booth construction methods to the current “temporary” construction requirements.

For the past few years The Fair has been encouraging the evolution of booths and other construction projects to keep our traditional appearance while requiring booths that are either completely removed or partially removed after the fair.

We have done this for a number of reasons:

- Land and environmental ethics and response. We need to construct in ways that do not block the sun and rain from the ground and do not aggravate flood conditions.
- We need to reduce the time, money and materials consumed in repair and maintenance.
- We want to construct in ways that use less wood, leave less wood out to decay, and are easier to set up and take down. By taking your booth home we hope you can use it in other ways during the rest of the year.
- Temporary booths create an easier relationship with The Lane County government.

### *Where are we in this process:*

The Fair has been encouraging fully removable booths and partially removable booths (the “bones” of the booth can stay but the “skins” of the booth cannot) for several years now. Many booths have evolved in part or in whole. The Fair recognizes that booth construction has been an organic evolutionary process, reflecting the changing needs of boothholders and

.....

.....

degradation of booths and site as a result of time and weather. This OCF Booth Construction and Maintenance Manual is intended to guide the conversion from permanent to temporary construction, and The Fair recognizes that this transition will require communication, cooperation, and effort.

Where we "are" right now is stuck playing custodian to hundreds of funky, deteriorating wooden booth structures that support some of the most magical social situations and the context for perhaps the most spectacular craft displays on earth. The problem is that many of them are in the wrong place, and have roofs, floors or walls that need to become removable and are in various stages of decay.

Many of these structures were constructed with little understanding of their current relationship to the site - the traffic flow during the fair, the plant communities during the rest of the year, the fungi that consume them year-round, the river that inundates them and sometimes carries them away or scours the soil around them, and their interactions with adjacent structures. Over the past decade or so The Fair's construction crews, site managers and operations management staff have developed a pretty clear understanding of the way booths, fences and other structures interact with the site and with one another.



Maintenance of permanent booth structures carries a high cost to the Fair Family in terms of labor, materials and risk. One of the stated goals of The Fair's Land Use Management Plan and of this revision of the OCF Booth

.....



.....

Construction and Maintenance Manual is to reduce the cost of maintaining The Fair's investment in infrastructure and booths.

*The Land Use Management Plan (LUMP)*

The LUMP is the Comprehensive Land Use for the Oregon Country Fair and it reflects many years of work and input. It provides the direction to manage the maintenance of booths through the Booth Construction and Maintenance Manual and the booth inspection process. The intent is to guide the evolution and maintenance of the fair's fantastic collection of temporary structures.



*The Basic Idea*

How booths are built and maintained at the Oregon Country Fair has always been an evolutionary process. This manual is intended to provide an overview of what we know about building things on The Fair's site and to explain why we are asking boothholders to do things in ways that at times are sure to seem very inconvenient, especially in those final few hours before the fair opens!

The Basic Idea section is intended to provide an understanding of why we have a Construction and Maintenance Manual for the fair, which activities and structures are covered by The Fair's construction permit process, what the process entails: what you can expect to have to do in order to

.....

.....

acquire a permit to build something new or repair or replace something that has reached the end of its useful life.

**Non-conforming structures**

The path from where we are to where we need to be is also evolutionary. OCF construction policy is to "phase out" nonconforming structures, and replace them with appropriate structures as they reach the end of their useful lives. The inspection and permitting process provides the means to implement this policy. New non-conforming structures will not be permitted, and permitted repairs to non-conforming structures must contribute to bringing them into conformance with current OCF policy.

This "phase-out" process is a general policy, but The Fair reserves the right to condemn a booth or a portion of a booth if necessary and to require changes be made to booths to make them more portable, long before their non-removable features reach the end of their useful lives. The process of speeding transition to compliance with current portability requirements may in some cases operate separately from the Red Tag inspection process that are in place primarily to addresses mechanical defects.

*The process begins with inspections*

Every spring approximately two months before the Fair, Construction Crew inspects structures at the site, including all craft booths. Extra detailed inspection is required for booths that have storage lofts. For example, a five-pound short handle "sledge" is used to soundly thump all storage loft floorboards. The inspector notes cracking sounds and, if warranted, does further "thumping," sometimes breaking right through! Posts and joists are probed with a screwdriver to locate rot. From the ground and up in storage lofts, attempts are made to sway and shake the booth. Even non-structural parts of the booth that are loose are noted to inform the booth representatives. Construction Crew also notes the presence of hornet or wasp nests for removal by Fair crews if they should stumble upon them.

Why does The Fair do this?

For one simple reason – SAFETY FOR ALL.

**Notification of Defects**

Every attempt is made to inspect all structures before "booth claim" day. In most recent years Construction has been able to send information to booth representatives describing repairs that will be needed. In this and future Fairs we hope to have early inspections and notices mailed at least 3 to 4 weeks before the Fair. However, sometimes weather or personal

.....

.....

commitments slow us down. If you suspect your booth may have "defects", it is best to call the Fair Office and leave a message for the Construction Coordinators. There is usually a Construction Coordinator at the Fair site for at least a month before the Fair to consult with booth representatives, fixers and builders.

Although The Fair inspects the booths, the actual boothholders have the ultimate responsibility of making sure that booths are structurally sound and safe. The boothholders should conduct their own inspections before and after modifying, repairing or using the booths.

**Formal Notice of Booth Holder Liability and OCF Non-Liability**

The Oregon County Fair assumes no liability to boothholders, guests, or members of the public resulting from any injury to person or property caused by or related to any structural failure, collapse, or design flaw of any booth.

**Construction permits**

*OCF Land Use Management Plan (LUMP) provides direction for booth construction goals and footprint and traffic Impact review.*

*If a booth has significant walls, roof or floor elements, it could be considered permanent by Lane County and would require a different permit process. This is why permanent booths are no longer allowed and why all booths on our site must evolve into temporary structures.*

**Goals of the OCF Permit Process:**

1. Assure that structures are as safe as can be expected.
2. Assure that all structures meet requirements of the LUMP, Guidelines, and Booth Construction and Maintenance Manual:
  - minimize waste of materials, from both short term and long-term perspectives
  - prevent erosion and loss of land or infrastructure
  - prevent harm to plants, animals and the land
  - minimize traffic impacts and maintain booth setback requirements
  - improve alter-abled access
3. Address other Booth Construction and Maintenance Manual requirements:
  - standards for a non-permanent structures
  - requirements for structures located in frequently flooded areas
  - suggest possible solutions

.....

.....

4. Note: The Booth Construction and Maintenance Manual does NOT address the needs of some important jurisdictions with authority to regulate activities in booths on our site, not limited to:

- County Sanitarian (Health Department) who reviews food booth issues
- County Fire Marshal who visits site at least once before every fair

*Implementation of OCF Goals through the Permit Process*

OCF has adopted its own Booth Construction and Maintenance Manual to provide standards that address safety and aesthetics. It still allows great flexibility for creative and artistic interpretation. The OCF permitting process is structured to encourage and accommodate innovation and good ideas. Numerous examples in the form of sample drawings and photographs of elegant solutions to common problems are provided in this manual to help guide your efforts.



Image 1: Four very different ways to support a storage loft

These four very different approaches to supporting a loft illustrate the enormous number of ways to satisfy the requirement that the structure be kept safe and sound.

How do I know if I need a permit?

The following table provides typical examples of repairs to structures and modifications that require permits and typical repairs that are often exempt from the permitting process. Use this table as a guide, but you should consult construction if what you want to do is not specifically listed.

Permit Triggers

Certain kinds of activities "trigger" others and it is in our stated intent to avoid or discourage activities on our site that would trigger actions from outside agencies.

Table 1 OCF Construction Permit Triggers

OCF Permit Typically Required	OCF Permit Typically Not Required
Structural Repairs to Booth Frames	Storage bins
Structural repairs to Lofts	Shelves
Structural repairs or replacement of floors	Counters
Structural repairs to railings	Non-structural work
Gray water dry-wells	Minor repairs to floors and railings.
Structures to support water barrels	

How do I know if I need OCF Plan Review?

Because some permit processes require plans, and some do not ...

**OCF Plan Review - Is it Required?**

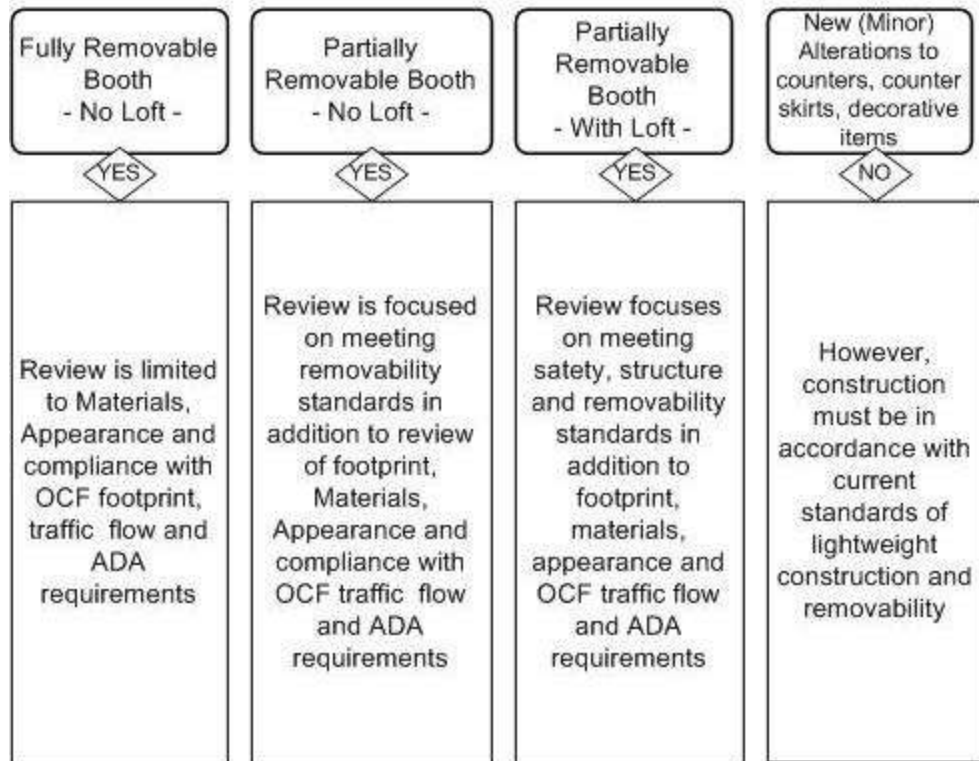

Figure 1 OCF Plan Review - is it required?

.....

*The OCF Permit Process*

**The entire Permit process can be summarized as follows:**

- A. New construction, if not exempt from permit or plan review, triggers permit process and plan review
- B. After annual Inspection, Construction Crews notifies the official Booth Representative of defects by email or phone and/or the famous Red Tags, posted on the booth.
- C. The Booth Rep can contact Construction Crew at any time to express their desires to repair, rebuild or even completely tear down and build a new booth. Contact information is provided in the final Appendix of this document.
- D. The Booth Rep or someone designated by the Booth Rep determines if permit is needed and submits the permit packet to Construction for review.
- E. The Construction Coordinator reviews application plans, drawings and notes to be sure they meet applicable structural requirements, traffic goals and aesthetic and materials criteria.
- F. The Booth Rep notifies construction that work is ready for inspection
- G. Construction Crew has the right to not approve the repair as actually done and to require corrections. Sometimes our best ideas don't work out and we don't know until we "shake it."
- H. Assistance is available by phone, email ([office@oregoncountryfair.org](mailto:office@oregoncountryfair.org)) or snail-mail year 'round (address provided below) or in person at the site for a month (weekends are best) before the Fair.



Here is a good example of the power of Nature during the off-season here at the site.

This booth was knocked entirely off its foundations and into the path by the recent floods.

Outline of the Permitting Process

The OCF permit process “flow chart” (try this as a parlor game and see if your friends take the same path you did!!)

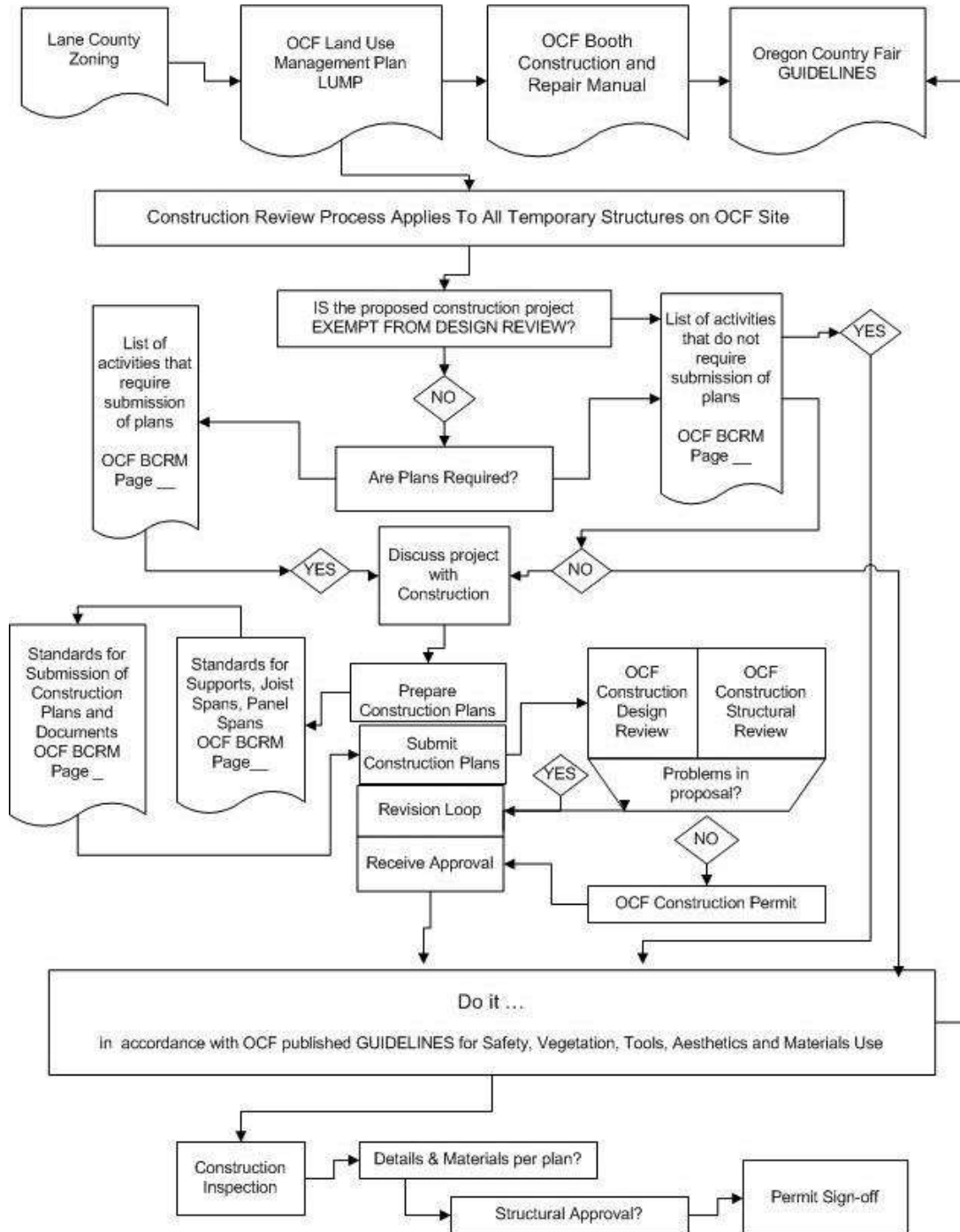

Figure 2 OCF permit process – Overall Permit and Plan Review flowchart

The "RED TAG" PROCESS

In the event that the OCF inspector red tags your booth, the following flow chart should get you from "Red" to "Clear"

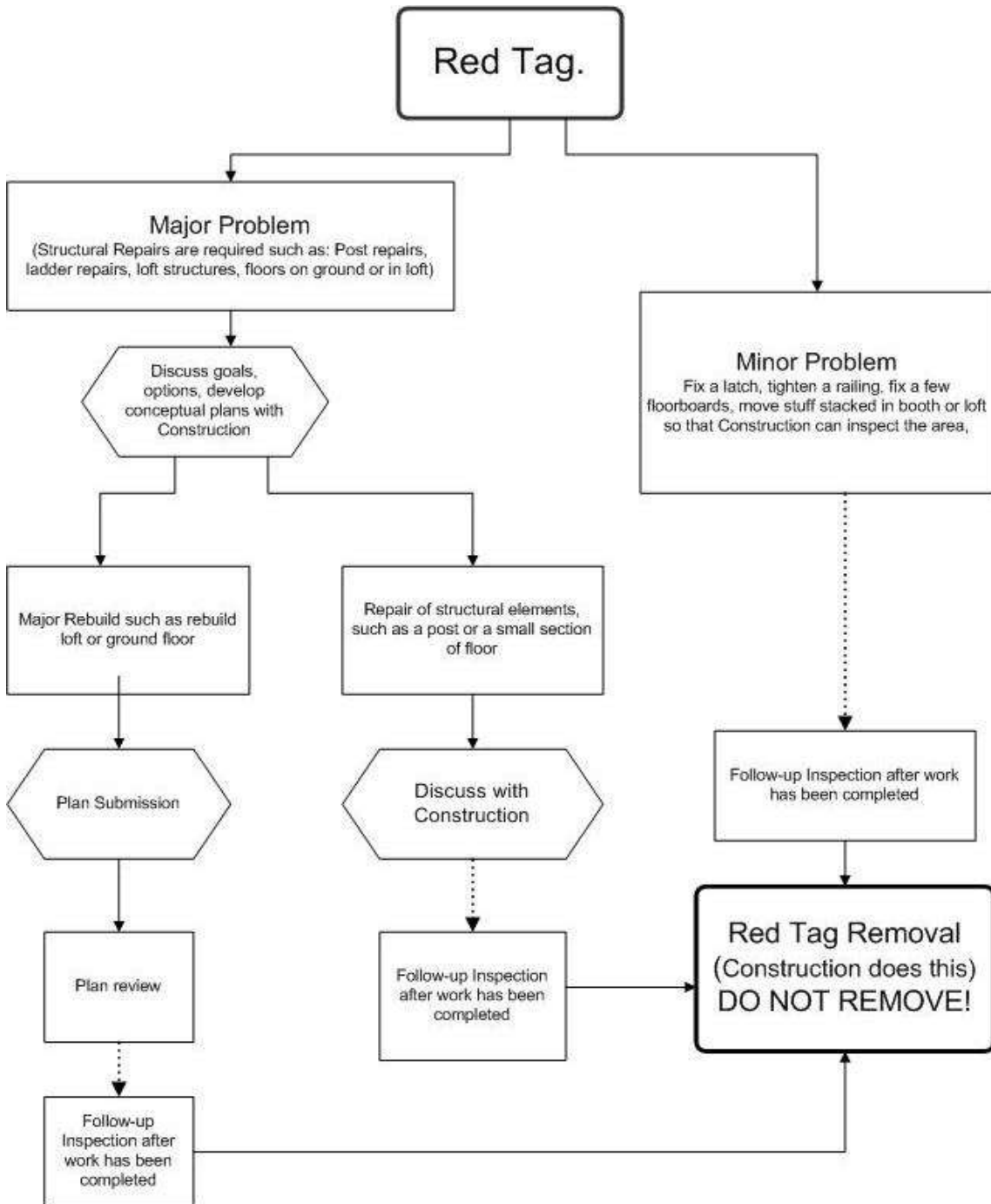

Figure 3 The OCF permit process - Red Tag flowchart



*New Construction (or Major Rebuild)*

*Getting the work done:*

While working on our site, all Fair Guidelines published in the Oregon Country Fair Guidelines book **MUST** be followed.

This means:

1. Check in with Registration when arriving on Site.
2. No brush cutting,
3. Secure permission for use of gas powered tools or generators,
4. Fire extinguishers must be within 10 ft. of any gas powered equipment,
5. Cut non-reusable wood small enough for easy OCF removal,
6. Check with quartermaster (in Main Camp) before you dig.
7. Notify Registration of all changes in Booth before leaving the Site.

Procedure:

Workers should check in with the Construction Desk in Main Camp when they first arrive. Construction Crew will be glad to provide assistance and advice on construction design and details.

Booth boundaries, setbacks, etc. should be determined PRIOR to beginning construction. Dispute resolution process is outlined in Guidelines.

When work is completed, The Construction Desk should be notified as soon as possible.

A Construction Coordinator will conduct a final inspection. This might even occur on a weekday, so sometimes the Booth Rep won't be there. A Construction Coordinator will later record work "cleared", and remove the red tag.

PLEASE DO NOT REMOVE RED TAGS YOURSELVES. The red tag is part of the record keeping process.

All Fair staff (especially Construction Crew) realize that many people involved with booths come long distances and often cannot afford to make several round trips to the Fair Site in the month before the Fair to repair their booth. By phone, email and/or by mail, Construction will try to assist in every way.

Phone Calls to the Construction Crew: Fair policy has always been that Construction Crews may return your call "collect." It is best to call on weekends when the full crew is there. Call the office (541) 343- 4298 and your call will come to the site during the last month before the event. And please note that sending email to [office@oregoncountryfair.org](mailto:office@oregoncountryfair.org) is often cheaper, easier and faster.

.....

*After the Fair/Yearly Maintenance*

Main Camp closes quickly and Construction "tears down" the fair in the first few days after the event. After many weeks of putting things together, it takes less than a week to store the reusables for next year. For this reason, Booth Reps must see to it that all required post-fair booth activities are done quickly after the final day of the event so that time exists for Construction to inspect all booths and sites for compliance with "close-up" requirements.

Required Post-Fair booth "close up" activities

1. All refrigerators left on the property must have DOORS and latches REMOVED immediately after the event. Doors left on are against the law and pose great danger to children.
2. All refrigerators must be removed from the property by July 31<sup>st</sup>. After August 1<sup>st</sup> a removal fee of \$25 per unit will be assessed.
3. Straw or other ground coverings must be removed. Straw floor coverings are environmentally unsound, and we recommend using burlap or reed mats. Regardless of what material you choose to use, you must remove it after the Fair. Pack it in, pack it out. Do not leave it on our site.
4. Ladders to storage lofts MUST be removed from the site or NAILED down or otherwise secured IN the loft. This greatly inhibits vandal access during off-season.
5. Removable wall panels, floors, counter skirts, etc. MUST be dismantled and stored. If any booth materials or components are stored on site they must be stored in loft or above possible flood water inundation, and if stacked for storage, they must be properly "stickered." All materials and components stored on site will be inspected next year.
6. Any stools, boxes or other "float-ables" should be placed in storage lofts or otherwise nailed or secured to the booth. Any item left secured to a booth MUST be at least 3 feet from the ground.

*Refrigerators and removable booths must be removed from site and all other components must be removed from site or secured to structure at least 36 inches above ground by July 31. Booths that fail to properly "close-up" may be subject to fees or other actions.*

*See end-of-fair checklist at the end of this book for more detail.*

.....

Suggested additional Post Fair booth "close up" activities

The photo below shows all the loft materials stacked and secured to loft railing, protected from accumulation of leaves and effects of weather by the counter skirt



DATES TO REMEMBER

*Removable booths must be removed from site and all other components must be removed from site or secured to structure above ground by July 31.*

*All refrigerators MUST be off site by August 1.*

*Booths that fail to properly "close-up" may be subject to fees or other action.*

that serves as a covering. This is an excellent detail, but in addition to the protection afforded by the covering, if these loft planks are left on site next winter, they must be "stickered" to prevent rot.

Before breaking camp there are some other things you can do to make set-up for next year's event easier and even better for your booth.

- 8. Clear the loft of anything that will trap leaves, debris and water. Lofts that can drain "off-season" last a lot longer than those that hold moisture in puddles.
- 9. Check posts, studs, joists and floorboards for soundness and sturdy connections
- 10. Shake it to see if additional bracing is needed.
- 11. Make sketches of the booth's posts, beams, joists, etc. to aid in off-season planning for work next year.
- 12. Expect to make structural changes to your booth to make it more portable with each passing year.

This list occurs again at the end of the Manual, as a checklist to be filled out by the Boothholder or Booth Rep who has verified that all floatable materials have been removed or secured.

## DESIGN GUIDELINES

### *Meeting LUMP requirements for Temporary Structures*

The LUMP requires that all new construction result in temporary structures, and as this applies to booths, at the minimum, it is expected that a booth will be designed to allow it to be quickly reduced to nothing but bare bones at the end of the fair, and that everything but the bare bones will be removed and stored.

Whether your booth frame is going to stay on site or go home in your vehicle, there are many rules to comply with. The most important involve safety: safety to the fairgoers, to the land, and to adjacent property owners in time of floods. The

.....

rest involve aesthetics and her twin sister, ethics. The fair is about theater, and about magic. These booths are the structures that support the magic, and the sets on which the theater occurs.

The Fully Portable Booth: bones, skins and portability

Over the past few years a vision has begun to "gel", a vision of fully portable or semi-removable booths; of structures made of panels that hinge or disassemble or even roll up for easy removal and non-motorized transportation to and from the site.

Most recently constructed booths have been designed around a fairly traditional post & beam structure, built from poles, bamboo or dimensional lumber. This post and beam constructed frame is "the bones of the booth" to which walls, counters, lofts, etc, are attached for use during the Fair and from which they are removed after the fair.

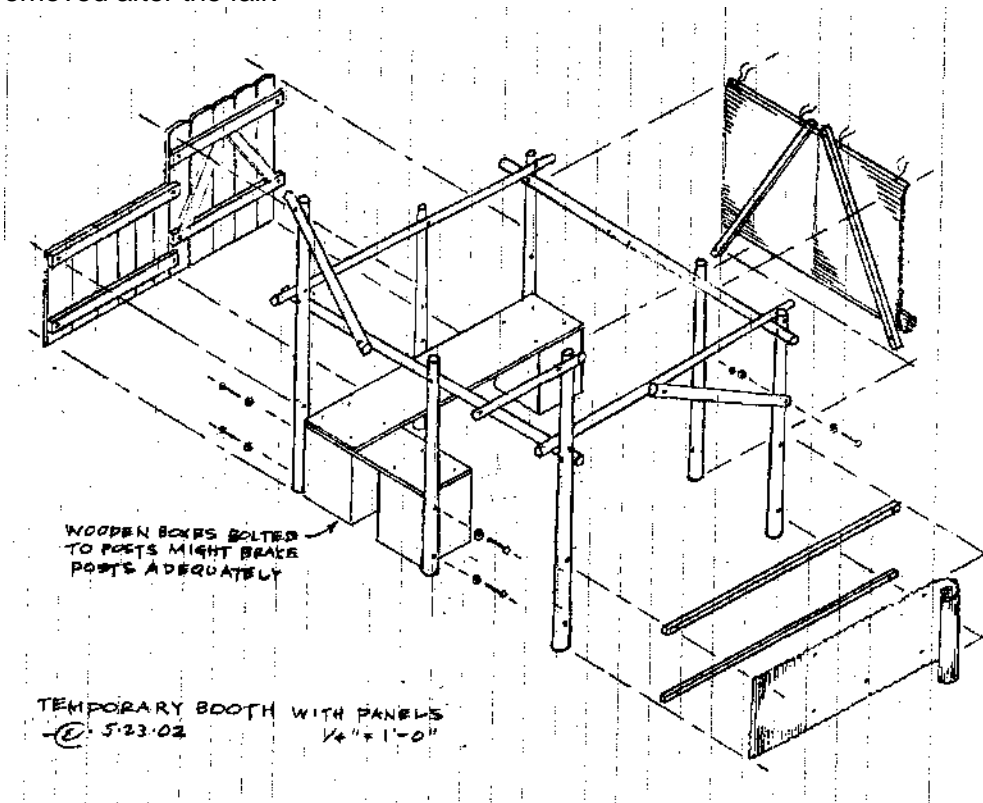

Figure 4 Schematic drawing of a pole-constructed temporary booth 2002

*General Design Guidelines (apply to all construction):*

We have been evolving how we design booths for some time now. The goal is to satisfy the LUMP's requirements to have non-permanent structures in the flood plain, and to create lighter-on-the-land and flood-sensitive booths. Our traditional building practices have wasted a lot of wood. We have shaded a lot of ground, preventing plant growth, and have screwed around with the flood patterns on the site.... it is high time for us to evolve.

.....

Aesthetics:

See The Oregon Country Fair’s annually revised and republished Guidelines. But in a nutshell, creative, playful, organic, handmade, and no plastic or blue tarps!

Plastic, plywood, concrete, metal, lattice from Home Depot and other such “manufactured looking” items are either not allowed or severely limited.

Portability:

The best booth is a lightweight wood (bamboo?) and cloth model that leaves the site 100% after the fair. It’s best for the land and groundskeepers, and the booth will last a lot longer in your garage than it will out in the woods!

100% removable booths are mandatory at sites within fifty feet of the river.

In other locations the idea is to have only the bare bones of a booth remain. Wall panels, counter skirts, counter tops, floors, all need to be removable (screws and duplex nails work well!), and either taken off site, or hinged or lashed securely up above flood line on **one** of your walls.

Although The Fair’s general policy is to require transition to portability standards through the Structural Inspection and Red Tag process, The Fair reserves the right to require changes to existing booths to make them more portable before they have deteriorated structurally to the point where reconstruction would be required solely on structural grounds.

Alter-abled Access

LUMP calls for absorbing traffic inside booths where possible and floors are difficult to integrate with this goal while providing access for alter-abled customers. Because they do not require ramps, ground-level floors are preferred: they create fewer access obstacles (compared to raised floors). As explained in other sections of this manual, removable floors are much easier on the ground and are therefore required.

Entrances to inner booth areas must be at least 36 inches wide to allow for wheelchairs and a clear space for a 5 foot diameter turnaround is also required. Steps onto inside floors create obstacles to access. Ramp access or threshold nosing is required. The proper incline for a ramp is 1 inch rise in 12 inch run.

Countertop heights should be designed with consideration of alter-abled access. This typically means that part of the booth’s counter should be designed to provide service to wheelchair customers.

A high forward reach of a maximum of 36 inches from the floor and a side reach of a maximum of 54 inches is also needed.

Booth Setback Guidelines (per LUMP):

Booths must fit into the space designated or space occupied by prior booth and must NOT intrude further into path.

.....

.....

Footprint/Traffic Flow:

Anything in your booth that projects into a crowded pathway is a potential safety problem, but even if your booth itself does not project, the traffic you stop can block traffic on the path and create problems. If you do not plan for your traffic impacts, you can create problems for yourself and for others. For this reason, increasing the size of the paths is a stated goal in The Fair's LUMP and required rebuilds of a booth's "bones" will often trigger "footprint review."

If traffic analysis shows that booth activities cause congestion problem, re-design may be required. Movement of booth may be required to mitigate existing congestion problems.

Draw a line between endpoints of walls of adjacent booths. No part of your booth may extend beyond this line. If your booth fronts directly onto a path, and provides no means to accommodate visitor or customer traffic inside the booth, visitors to your booth should not extend past this line, either.

*Basic Design Standards (apply to ALL booth structures)*

Vegetation Management

Brush clearing is strictly prohibited. See Guidelines for details and explanations -- see Vegmanecs for assistance.

Storage Lofts

Only one storage loft area of a maximum floor area of 100 square feet is allowed per booth.

No free-standing storage lofts are permitted. Your storage loft MUST be part of your booth, not a separate structure.

All horizontal structural parts (except bracing) must clear the ground by at least 6 feet 8 inches.

No storage loft floor may be higher than 8 feet from the ground.

All storage loft floors, handrails and closures must be sound and solidly fastened.

No permanent roofs are allowed (bunting supports are allowed and could be used for emergency rain covers).

Water Barrel support

Water Barrel support structures design must support at least 500 lbs. weight per barrel. See Construction Desk in Main Camp for a detailed drawing of appropriate water barrel support structure and for gray water dry-well details.

.....

Exposed Fasteners

Exposed fasteners, including nails, should be galvanized - many booths have demonstrated that even large fasteners such as through-bolts and lag screws can be hidden from public view (typically they are disguised with caps made from sections of tree branch or other natural materials). **DO NOT NAIL TO TREES!**

*Specific Guidelines for Booth Components*

Structures that might break loose and float away

The Country Fair's site is located in a frequently flooded area. Much of the site is inundated by water at least once a year. When the Long Tom River floods, currents can be very powerful and structures that obstruct or impede flowing water can create serious erosion and loss of land. Structures that break loose and float away can cause even more serious problems, both to adjacent booths and to adjacent property owners.



This may come as a surprise to many, but this is our site manager canoeing in Miss Piggy's on the first day of flood season. It is almost hard to believe this is the same place where thousand of cars park during the Fair.

Excellent and informative images of the site during winter can be found in the Caretaker's Journal linked from the OCF Website.

<http://www.oregoncountryfair.org>

LUMP REQUIREMENTS APPLY TO ALL STRUCTURES:

The LUMP states: "Secure floatables to prevent flood transport"

Roofs

During the fair, roofs provide welcome shade, but for the rest of the year they create environmental problems. Permanent structures are not permitted on most parts of the site. The LUMP calls for Temporary structures for most of the site. Roofs are characteristic of Permanent structures and therefore they are non-conforming uses and non-conforming uses will be phased out.

.....

Roofs red-tagged as "in need of repair" must be replaced with more appropriate solutions, using approved construction methods and materials: cloth or other easily removed organic "fair like" items.

Examples of Appropriate roof materials:

- Cotton Canvas
- TieDye Fabric
- Bamboo
- Cane



Lofts

As shown in the Permit table, and described in the discussion of permitting below, getting a construction permit for a new booth with a loft is a pretty serious undertaking, and can seem next-to-impossible, especially on short notice. There are options though, and innovative design can get around many of the obstacles involved and avoid creating a permanent structure.



Most of the year, the site belongs to nature – to the plants and the animals who live here.

Anything that blocks the sun and the rain interferes with life or filters and selects in favor of some organisms at the expense of others.

Ironically, nearly all of the processes we use to cover the ground with boards selects for organisms that devour wood.

Here we can see telltale signs of fungi devouring floorboards.

.....





Note white fungi devouring floor joists in this loft. Note that all the gaps between floorboards are plugged with leaves. Even if the loft manages to stay leaf-free, the “permanent floor” that it creates still blocks light and in most cases it creates killing shade and other serious problems, as shown in the photo below.



**The most significant impacts to the ground, after floors, come from roofs and lofts.**

Look at the lines in the foreground of this picture:

... this is a pattern of drip lines. These rain-pounded furrows are over an inch deep.

Note also the near-total lack of vegetation in the area shaded by this loft in the INFO booth near Chela Mela Meadow

.....

Floors

Permanent floors are non-conforming uses and when they are found in need of repair they will be eliminated entirely (preferable) or in those instances where hardened floors are clearly unavoidable, replaced with removable floor sections.

These removable floor sections must be removed from the site at the end of the fair or made in stackable palette-like sections and secured above floodwater. Over the years we have discovered that floors really are not O.K. They will still be allowed in some cases, but they MUST be made in removable sections because the ground needs to live and the water needs to flow



Very few booths really need floors, but in those few cases where floors are necessary (such as some areas of some food booths) new or replacement floors must be made in panels that can be lifted up and stacked elsewhere at the end of the event, allowing the ground under the floor to heal. Old floors that need more than a few boards repaired must be either eliminated or made removable.

Any wood panels left on site will soon begin to rot and if unsecured, will float away.

Therefore, panelized removable floor sections should be removed from the site at the end of the fair. Wood left on site must be stacked and secured properly: loft planks should be stacked above flood water, stickered and covered, floor and wall panels need to be stacked on edge and covered.

Panelized floor sections stacked on edge, but too close to ground



This image shows panelized floor panels stacked and secured for winter. These panels are much too close to the ground to let light in, and so close to the ground that at some sites they would result in significant loss of soil during flood events, if they did not float away. Therefore, Guidelines require that all materials left on site after July 31 must be secured a minimum of 3 feet above ground level. Note: 4 feet is better in most areas.

.....

.....

Walls

Walls can be paradoxical. On the one hand, the Long Tom River floods almost every year and the forces of the flooding river can be overwhelming. Obstacles such as walls that impede its flow can be swept away, or create eddies and turbulence that lead to severe erosion. Walls also create shade. On the other hand, the miles of weathered wooden walls and fences at OCF seem to provide the ideal canvas for creative expression and for the creation of illusions. Layers of fragile patterns, marquetry, appliqué' and other labor-intensive techniques often result in panels that are too fragile, too heavy or large to move comfortably.

All walls must be removable and all but one of the walls must be removed at the end of the fair. The remaining wall must have at least a three-foot space at the bottom to pass floodwater. Cloth, bamboo, or other removable walls are much better. One full size wall with all the others removed and lashed or otherwise securely fastened to that wall (all attached material should be at least 4 feet above the ground and MUST be at least 3 feet above ground level) is currently considered acceptable, but the goal we are striving to achieve, and that we will require all booths to adapt toward, is "no walls left on site."

There is no discussion of wall-framed booth construction in this manual because lofts can not be supported by "stud-frame" house-style construction and this kind of construction is at odds with aesthetics guidelines and it is clearly "permanent." Such construction is not allowed on site unless you have agreed to remove the entire structure after the event.

**LUMP: "All Structures shall be temporary in nature."**

Booths with more than one permanent wall are non-conforming and when found in need of structural repair, must be rebuilt according to the standards below.

**Standard:**

Only one out of the four walls of a booth may be "fixed", but other walls, floor panels, etc. are to be removable and at the end of the fair, either attached to the fixed wall, above the reach of floodwater, or removed from the site entirely.



*Full skirt-boards can cause heavy erosion during flooding. Water is irresistibly forced to flow underneath them creating holes, washing away topsoil, and exposing roots--- as in this example. The water is also channeled down the paths, which has a similar degrading effect. We would suggest hinged, raised, gapped, or temporary skirts to help alleviate this problem.*

- Andy Strickland, OCF Caretaker

Hydraulic Damage from Walls and Counter skirts

.....

.....

The "fixed" wall, if left standing at the end of the fair, should end well above the ground. A 3 foot gap seems to provide a reasonable compromise between the needs of a wall and the realities of flooding water, except in areas of the site where flooding has been a consistent problem, in which case distance from the ground should be even greater.

Any materials attached to the fixed wall or other part of the booth must be secured (screws, duplex nails, etc.) a minimum of 3 feet above the ground per *Section 34 Booth Construction* in Guidelines.

Counters and Counter Skirts

Counters and counter skirts are really just more roofs and walls, on a smaller scale, and they create many of the same problems for the land.

Standard:

Counters and Counter-skirts must be removable. Counters that hinge up, so light and water can reach the ground, and skirts that can be unscrewed (or at least hinged) to allow light and floodwater flow, are mandatory these days. When it's time to rebuild these parts of your booth they will need to be made fully removable.

The obvious solution to many problems posed by counters and skirts is to remove the panels from the site at the end of the Fair, or get them out of the way.

Removable walls can take many forms. Current thinking favors roll-up panels.

Advantages of fully removable walls and counter skirts are that the materials involved can be low-cost, lightweight, fast to set up (compared to the time you would have spent repairing them if they had stayed on site all year) and will last a long time if they are stored out of the weather.

Disadvantages are that fabric backdrops and bamboo screens tend to get monotonous and that each screen requires external framing to support it, and to support shelves, hangers for stock, etc.

The preferred solution is to use stretcher-bars that support both the panel and the shelving or hangers. These stretcher-bars will increase the booth's diagonal strength and provide often-needed rigidity when added to older booths.

Look closely at the drawing examples in this manual and you will see what we mean.

.....



This image from last winter shows why we are so concerned about counter-skirts and how, from the point of view of the floodwater, they create just as many problems as walls. Water moves fastest near the surface, so the pressure is greatest in the top few inches of the flooding river.

Examples:

Some of the newer booths have implemented a complete integration of their counters, counter-skirts with their shipping containers. Obviously, these furniture-finished cases go home.

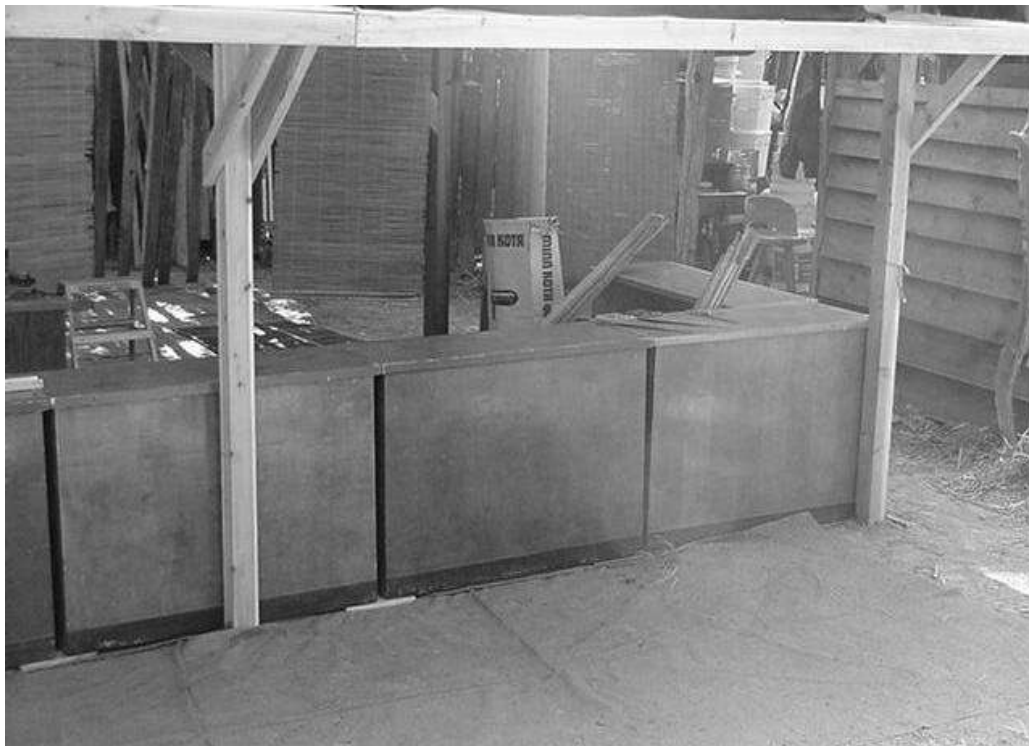

.....  
The booth drawings that follow illustrate this concept and others.

These drawings increase the level of integration over any of our past-years' booths by using the counters, walls and the stretcher-bars for the roll-up wall panels to provide the necessary triangulation to support the booth and the loft. Even the counters are bolted to the posts to increase rigidity.

Note that no post holes are required to support any of these booth designs.

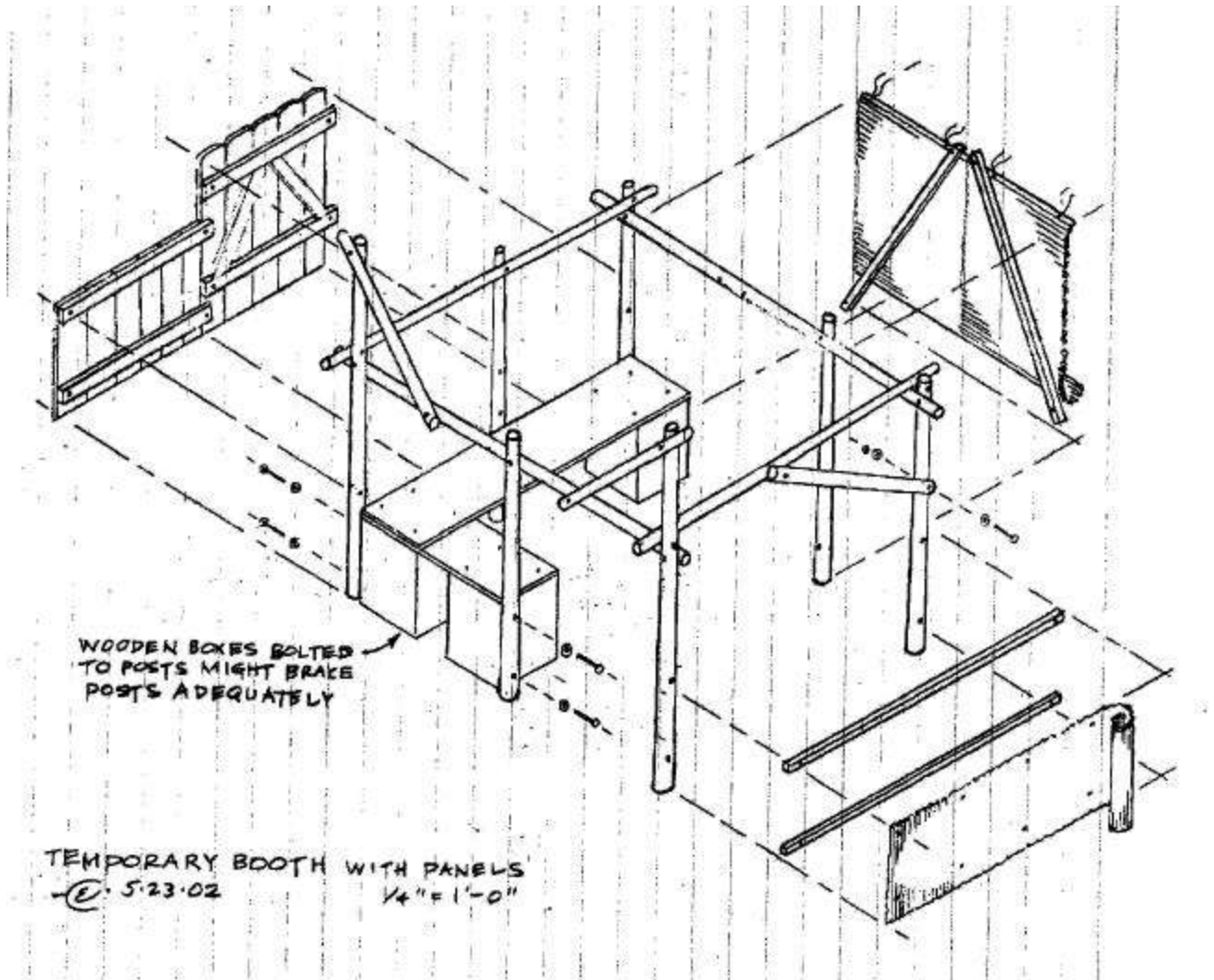

Figure 5 Temporary booth schematic with Integrated counters removable walls, and stretcher-bars

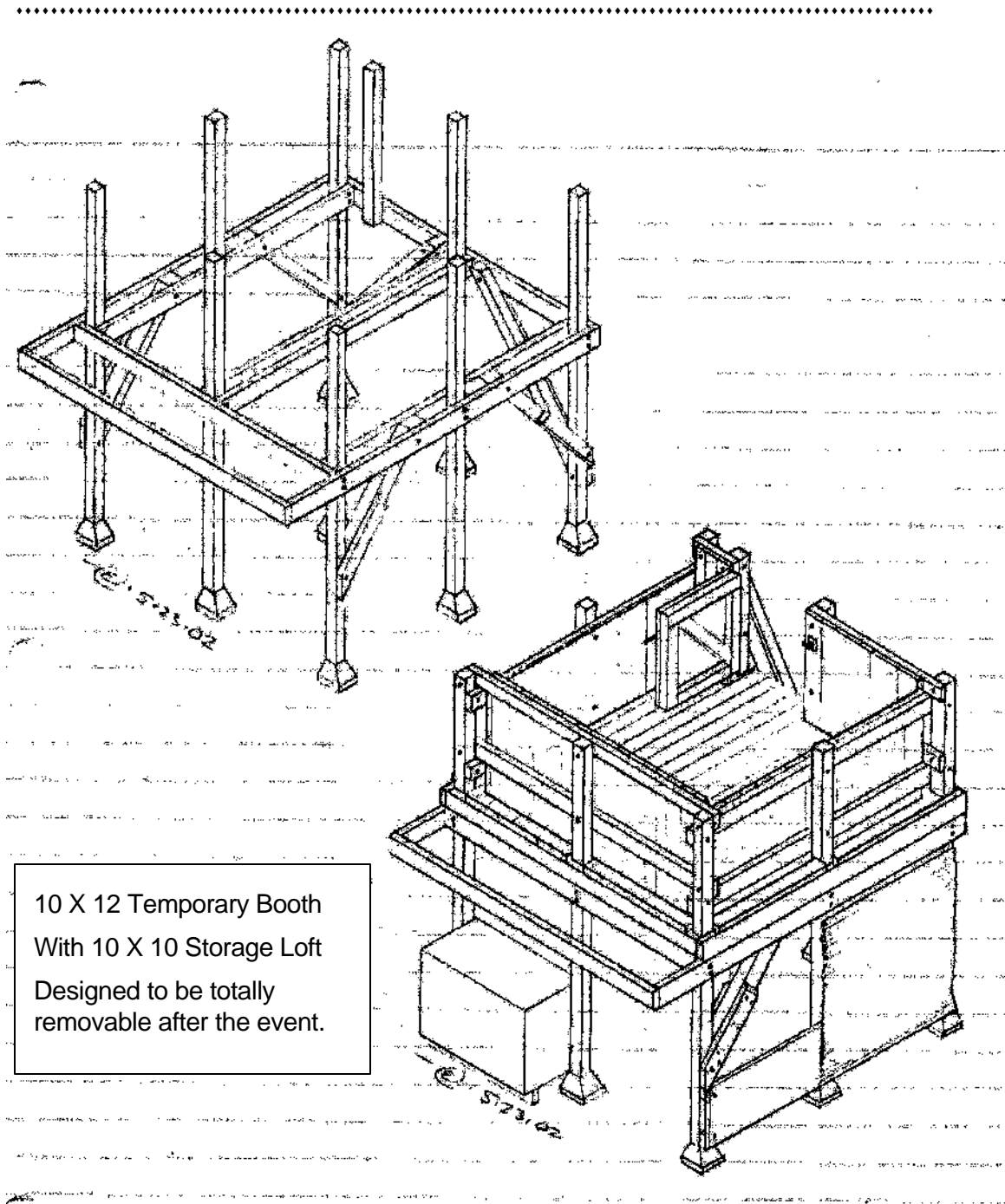

Figure 6 Temporary Loft Booth - framing diagram

### Engineering Definitely Required

Load calculations, clever joints, and serious diagonal bracing are required to support lofts in Temporary booths. Most existing lofts rely on large deeply buried poles to support them, rather than relying on sound engineering. Ultimately, as the posts that support these booths rot away, the structures become less safe. More detail regarding post and pole sizing and joist depths and spans require for

.....

booth construction is provided under CONSTRUCTION DETAILS, in the following section of this document.

Postholes versus post piers

If not within 50 feet of the river bank, in a problem erosion area, and not destroying brush or major tree roots, posts in holes can provide a solid anchor for a booth. Posts put in the ground should be rot resistant (but **can't** have high toxicity preservatives) and must be buried 30 to 48 inches, backfilled with dirt.

**CALL QUARTERMASTER BEFORE YOU DIG**

*Call before you dig*

Underground utilities

There are now communication and water lines buried throughout the site and if you start digging holes you may discover them by accident. Quartermaster should be able to advise you if you are in an area where there are buried lines.

Underground artifacts

Archeology is mapping the Fair site and is very interested in learning what turns up in any post holes, particularly in areas known to have been inhabited in the past. Current understanding is that soil depth accumulates at about 0.01 inch per year. So a 3 foot deep post hole might take us back 3000 years.

Quartermaster should be able to advise you if your booth is located in an area known to have supported human habitation in the past. If it is, Quartermaster can advise you who to find in Archaeology and they will help you approach the excavation in a way that minimizes potential damage to artifacts that may be buried under your booth.

*Reduce waste of materials*

Given the rate at which buried wood rots at the site, replacing buried support poles can become a major overhead cost. One solution to the problem is to NOT bury the support poles, and find a better way to provide the support required.

For those who cannot or would rather not dig post-holes, for repairs of buried posts that have rotted at ground level, and for portable and partially portable booths, concrete pier pads may prove to be the best method of anchoring the poles or posts supporting the booth. These are commonly 12" x 12" on the base sides and 8" high.

They must be covered or disguised during the fair so that they cannot be seen by the public. Burlap sacking is a good solution to disguise and soften concrete footings. But before you disguise them, you must demonstrate that there is a method (strap, slotted or pin) of securing your post or pole to the pad. The pier

.....



.....

pad must sit level on undisturbed soil - not on vegetation or filled-in dirt - so dig into the solid ground (to level the pier pad) only slightly and very carefully. Also, water travels through concrete by capillary action so a moisture barrier should be installed between the wood and the concrete if you intend to leave the post and pier on site over the winter.

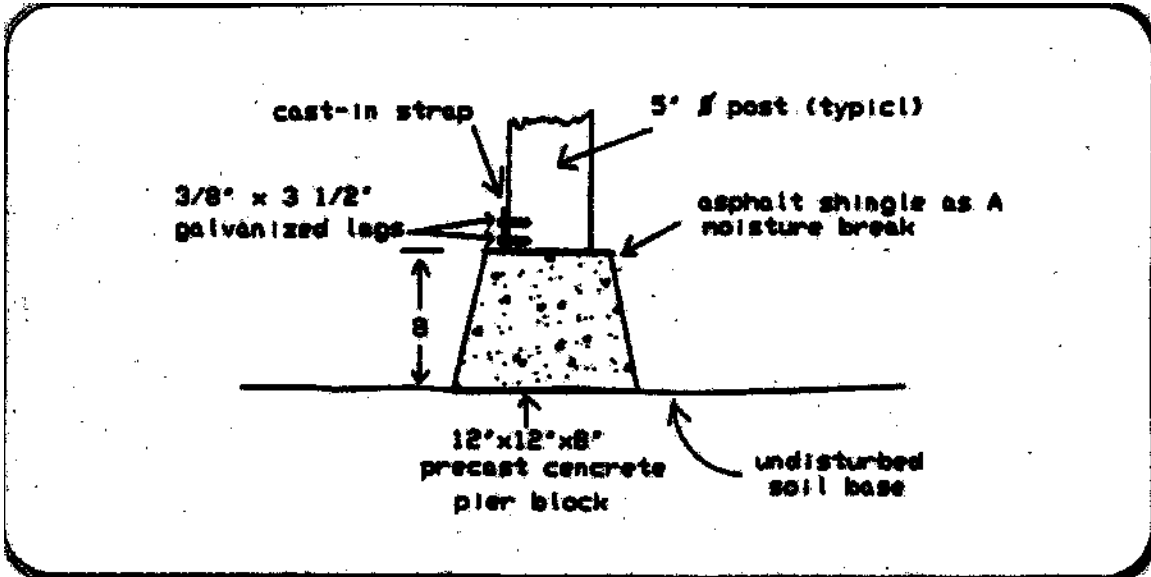

Figure 7 Post to pier pad attachment details



NOTE: Show us the bolts connecting the posts to the blocks. Then cover the concrete.

CONSTRUCTION DETAILS

The following images detail the construction of a fully portable Loft Booth.

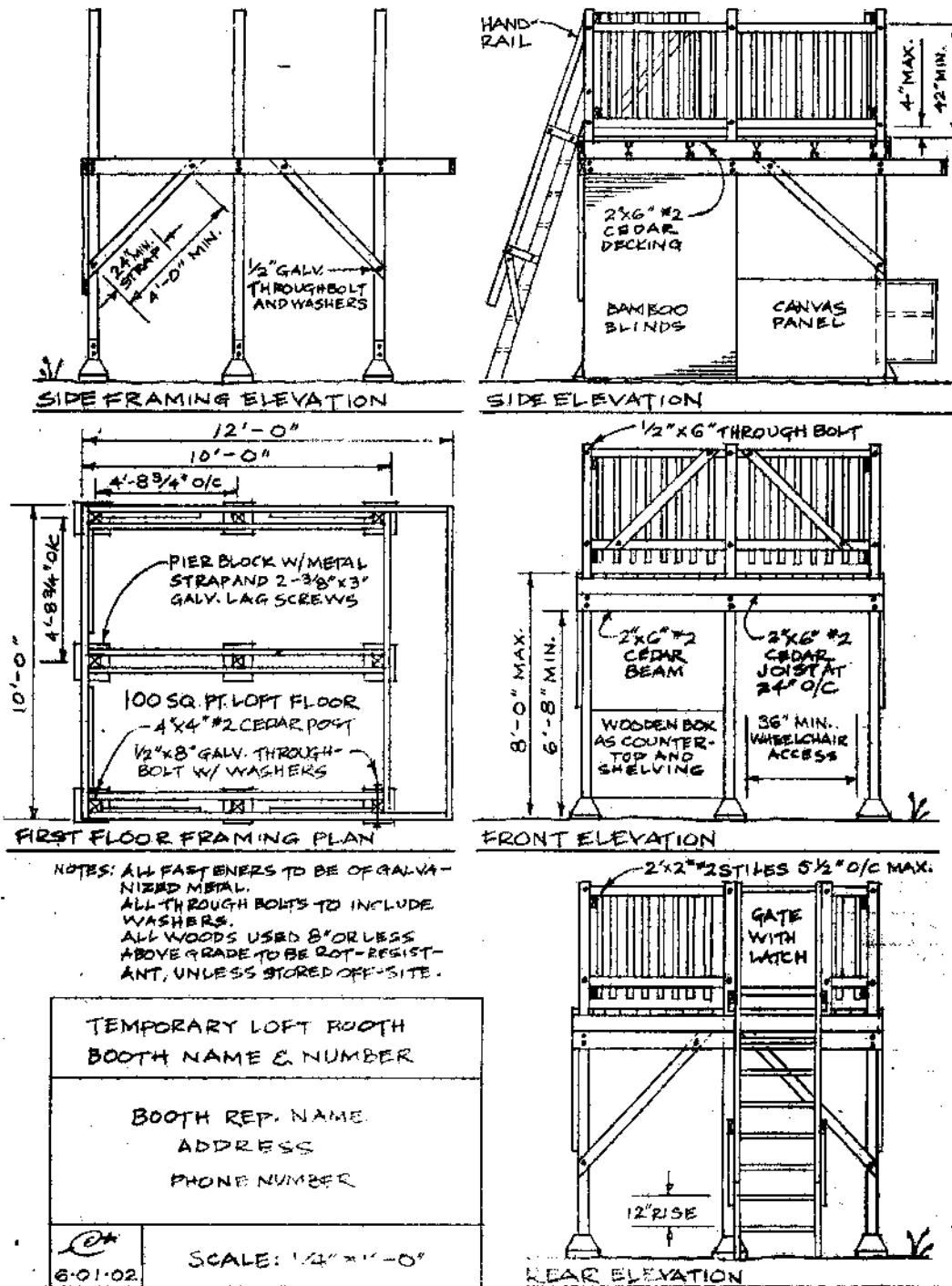

Figure 8 Sample Drawings - Framing plan and elevations for temporary removable loft booth

.....

*Details of Booth Construction*

Design of an Oregon County Fair booth is influenced by visions of builders, the aesthetics of the Fair, the immediate surroundings of the booth, the needs of the land, Lane County's zoning requirements, and this Construction Manual which serves as the rule-book for construction and maintenance of booths on the site. The Fair's Guidelines provide general guidance on booth design and construction.

The following sections provide more specific information to help you design for new booth construction. They should also be helpful in major repair projects.

**Please note:** If your booth will have neither a storage loft or a floor and it will be under 10' high, your booth may considered non-structural and all work may be considered "cosmetic." It should still be solidly built to prevent collapse but it might not require a construction permit, and may **only need** approval of rough plans by a Construction Coordinator for compliance with applicable footprint, setback and aesthetic (materials) guidelines. Check with one of them to see if you fit this permit "exemption."

Storage racks for Water Barrels and Dry Wells

Food booths often require features not utilized in craft booths. Most important are storage racks for water barrels and Dry Wells for sink drains. Neither is fully addressed in this Manual. Please see Construction Desk in Main Camp for latest drawings for Water barrel storage racks and dry wells.

Storage loft-size and load assumptions

Because there is a 100 square foot size limitation for storage lofts, let's assume the storage loft is to be 10 feet x 10 feet square (it could be just about any shape you want). Because there is NO PUBLIC ALLOWED in the storage loft, the assumed dead load of the loft itself plus stored materials, added to the potential live load of booth people accessing the storage loft will determine the sizes of posts, rim and header joists, floor joists and any other structural pieces needed. For this manual we will assume a potential live load of 50 lbs per square foot. Most residential construction codes assume a static load of 40 to 45 lbs per square foot but OCF booths should be subject to a somewhat higher design load requirement of 50 lbs per square foot because unlike residential construction, the structure of the booth is not protected from the elements.

Post and Pole sizes for storage lofts

For "Fair Engineering" purposes we will consider sound round poles and square posts as roughly equivalent. Because pole quality is less predictable than that of graded production lumber, we have set a chart that assures the posts/poles will be of roughly equivalent strength. The chart assumes the posts and poles are of Western Oregon softwoods -pines, firs, larches, etc..

.....

Post Sizing table for Loads of up to 2500 lbs. per post.

<u>Height of floor Load</u>	<u>3 x 3</u>	<u>3 x 4</u>	<u>4 x 4</u>	<u>4 x 6</u>	<u>6 x 6</u>
4 ft. or less	ok	ok	ok	ok	ok
6 ft. or less	ok	ok	ok	ok	ok
6 to 7 ft.	NO	ok	ok	ok	ok
7 to 8 ft.	NO	NO	ok	ok	ok

Post to Pole Equivalency Chart

<u>Post</u>	<u>Pole</u>				
	diameter at smallest end				
3 x 3	3"	"	"	"	"
3 x 4	3 1/2"	"	"	"	"
4 x 4	4"	"	"	"	"
4 x 6	5"	"	"	"	"
6 x 6	6"	"	"	"	"

Table 2 Pole size / post equivalency Chart

Procedure to determine size and number of support posts

To determine the minimum acceptable sizes and numbers of posts or poles needed to support a storage loft you can follow these procedures:

Measure (or design) the shape of the storage loft floor system and locate where the posts are or will be. Essential information will be: how many, how evenly spaced and how far they are spaced apart.

Compute the square footage of the entire storage loft area and then multiply that area by the required design load of 50 lbs/square foot. Example: a 10'0" by 10'0" storage loft -

10 feet X 10 feet = 100 sq. ft.: 100 sq. ft x 50 lbs/sq.ft. = 5,000 lbs. in loft.

If your posts are all evenly spaced under the load, like at four corners of a 10 x 10 storage loft, you can simply divide the load by the number of posts.

Example: 5000 lbs. divided by 4 means 1250 lbs. per post.

From the table above you can see that the height of the load on the post is also a factor in correctly sizing the post.

Other important factors include how straight the post is, the quality (grade) and rigidity by way of bracing or post set in ground. The tables in this manual provide a built-in safety factor because of these variables and because deterioration in the strength of the wood begins almost as soon as the post is buried.

Structural Requirements for all posts and poles:

All structural posts and poles must be:

- Sound lumber (it's much better to peel poles!--they will last longer)

- Fairly straight
- Secured at the base to a concrete pier or buried at least 30 inches for up to 8 feet exposed and 36 inches for up to 14 feet exposed
- Braced to the storage loft floor with cut-in knee braces
- Treated with approved decay resister if closer than 8 feet to ground level

Repairs to "grandfathered" storage lofts

If your storage loft is "grandfathered," larger than 100 square feet, and needs posts replaced it is quite likely that your new posts will have to be larger than the old ones that were done before the Booth Construction and Maintenance Manual's standards were applied to construction at the Fair. Consult with a Construction Coordinator.

Diagonal braces (short ones are also referred to as "knee braces")

Squares and rectangles are not stable building shapes by themselves. Solid siding or flooring helps stability, but triangles are the key. The item most often criticized by the building inspectors is inadequate bracing on Fair booths. The very best bracing method is to provide "2-by" (or larger) braces that reach from loft floor at one corner to the post bottom at the pier pad, going each way in an "X" pattern. All but the path-side front of the booth can be done this way and it is HIGHLY recommended to maximize stability.

Examples:

On a loft floor 8 feet high, diagonal braces at least 48 inches long should be used extensively if the posts are secured to pier blocks.

With posts that are set in the ground at least 30 inches, less bracing is needed, but remember – buried wood loses strength very rapidly.

Solid wood or plywood gussets can also be used if of adequate size, rigidity and method of attachment i.e.(big bolts, lag screws or lots\_of nails).

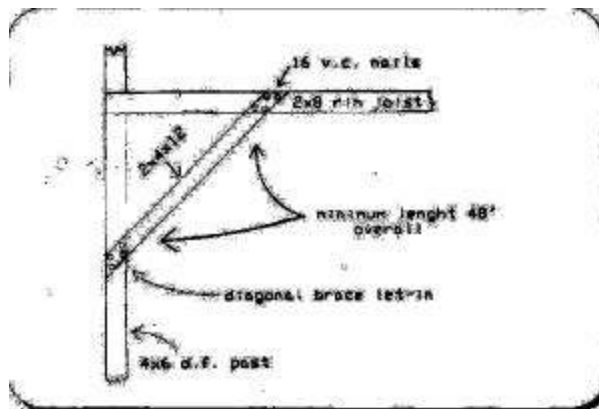

Braces should be securely fastened with bolts or at least 4 duplex nails at each end, in holes drilled to prevent splitting and should also be "let-in" for maximum effectiveness; that is, the braces should fit into notches cut for them.

Figure 9 "Knee Brace" framing detail. Show us this much detail in your drawings.



### Ground level floors

Ground level floors, like roofs, are characteristic of permanent structures and are therefore non-conforming structures. New ground-level floors will not be permitted unless they are removable.

Many recently built booths have included ground level wood floors. These have added to booth construction and maintenance costs, and create obstacles for alter-abled access, but they cut down on dust and mud generated in food booths and provide a flat walking and display surface.

Most of these floors will be replaced with more appropriate solutions through red-tag or other processes.

The size of the joists and floorboards required would be the same as for a storage loft floor, (See "Storage Loft Floor Joists" later in the manual), but smaller lumber can be used by increasing the frequency of supports. Consult with a Construction Coordinator for the allowable spans under these conditions.

### Ground Clearance

There is basically no way to keep leaves and other debris from clogging the gaps between floor boards. If you assemble the floor with small ( $\frac{1}{4}$ inch or less) spaces between boards, it will drain much better when things get wet, but the gaps will eventually clog and present problems. All untreated wood should be at least 8 inches from the ground.

A far better solution than a framed floor for most sites that need floors, is to design the floor as a set of removable panels that can be transported and stored,



.....  
because we have found that wood floors at ground level (read that FLOOD level) rot even faster than un-drained storage lofts.

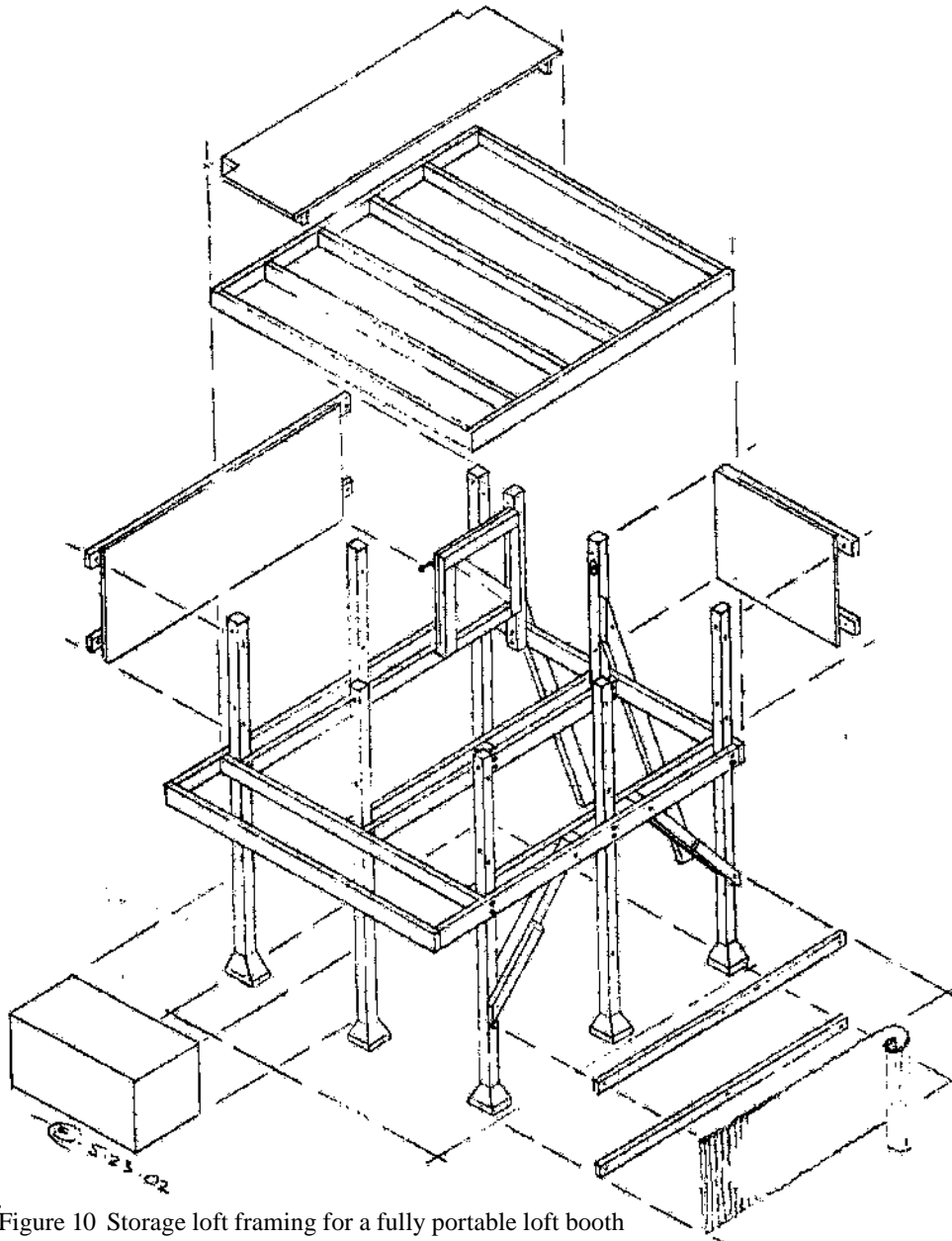

Figure 10 Storage loft framing for a fully portable loft booth

### *Storage loft floor framing*

The model 10 foot by 10 foot storage loft floor at 50 lbs/sq ft must be designed to carry a potential load of 5000 lbs. There are many allowable ways to frame the floor. What follows is a drawing of three different approaches to framing a storage loft floor and you can see that each offers a different combination of drawbacks and advantages. Parts are labeled so that we can all use the same names for parts.

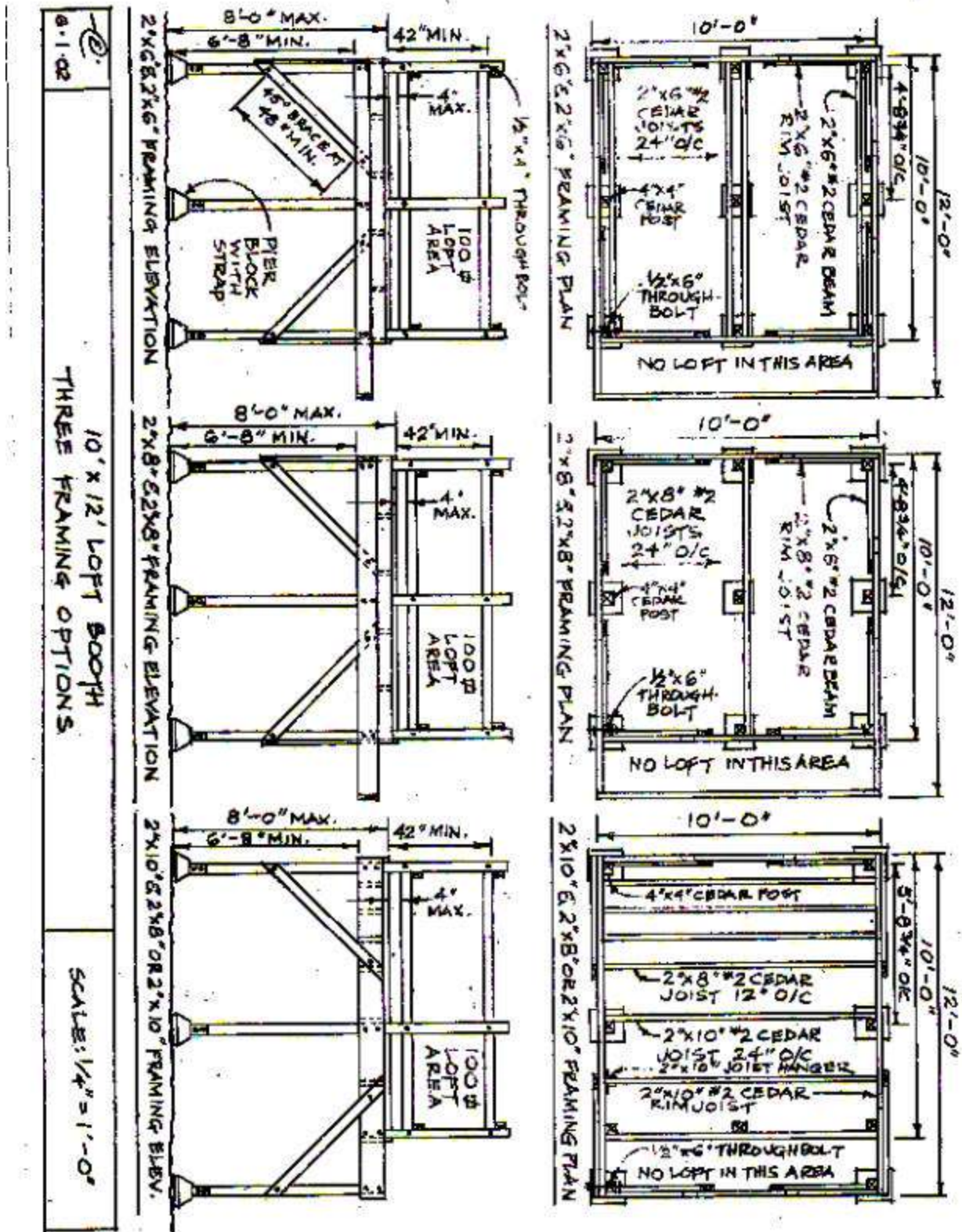

Figure 11 Example construction drawings showing three possible options for storage loft framing



Floor Joists

The size of floor joists for a storage loft depends on the span - the distance between the points where the joist is supported.

It also depends on the load (which our "code" sets at 50 lbs/sq. ft.) and how far each joist is from another joist (called the "on-center dimension") - shown as "O.C.".

Booth builders with experience in residential construction might think the size per span and span spacing shown in the drawing and tables we have provided is severely overbuilt, but the OCF Booth Construction and Maintenance Manual must address the reality that structures are often exposed to the elements and that a public event is involved and therefore a higher standard is required.

The following table has been simplified to take into account that almost no one at the Fair ever uses tongue and groove (T&G) lumber or plywood.

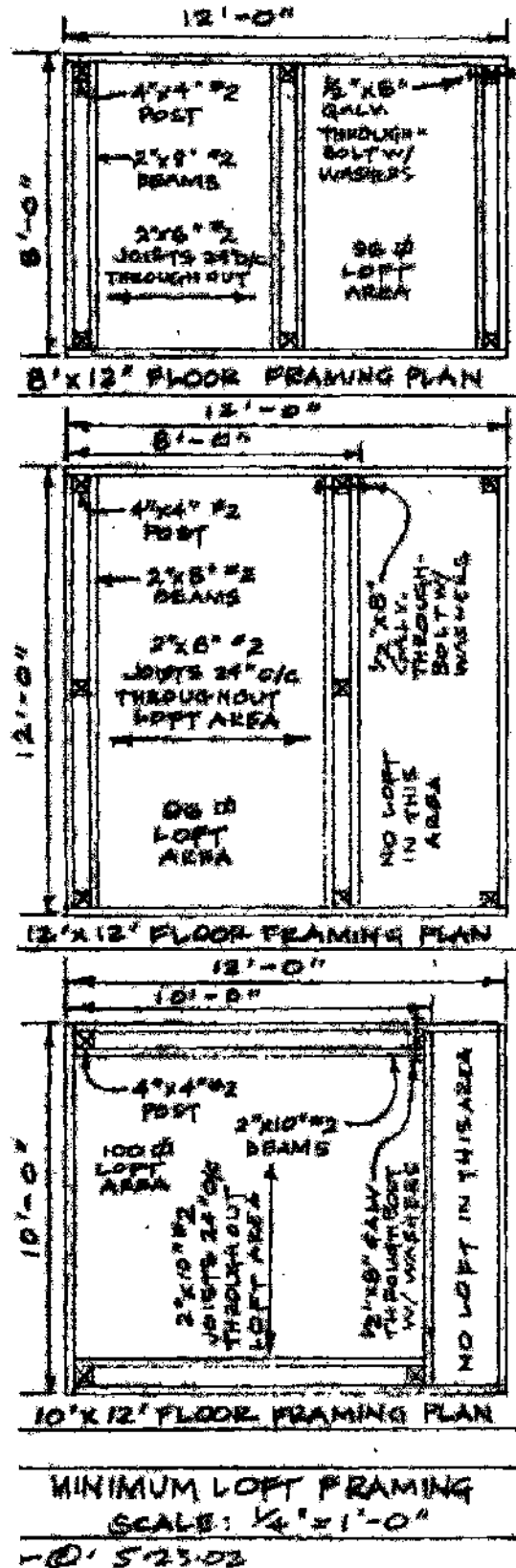

Figure 12 Minimum Loft Framing Options

Table 3 Beam and Header Joist Span Table

Beam and Header Joists - Span and Size Table		
Span is the on center distance between support posts		
Span	Double "2-by"	Single "2-by"
4'	2 - 2 X 6	2 X 8
5'	2 - 2 X 6	2 X 8
6'	2 - 2 X 8	2 X 10
7'	2 - 2 X 8	2 X 10
8 feet	2 - 2 X 8	2 X 10
9'	2 - 2 X 10	2 X 10
10'	2 - 2 X 10	2 X 12
11'	2 - 2 X 12	Not Allowed
12'	2 - 2 X 12	Not Allowed

In the preceding drawings the floor joists are resting on a pair of 2 x 10's at each end. The pair of 2 x 10's are bolted together through the posts with long galvanized 1/2 bolts at each post. This is only one of many ways to frame the floor. The floor joists could be hung with (hidden) metal joist hangers from a large header joist, the beam could be a 4 inches x 10" resting on top of the post with metal brackets securing it, parts could be notched in and so forth-lots of options.

*Joist Calculations*

If we assume that the lengths of the floor joists are supported only at the ends to keep space beneath the storage loft as open as possible, then we need another table to determine the minimum size of the header joists or beams necessary to safely carry the load. We start with the combined live and dead loads of 5000 lbs, divided by 2 beams which equals 2500 lbs per beam. To find the depth of an assumed "2-by" beam you can use the following formula for odd lengths or use the table provided below.

The tables and formulas below assume #2 or better Douglas Fir which has a modulus of elasticity value of 1,500,000.

Span/depth calculation for beams

$$d = \sqrt[3]{\frac{8100 \times w \times L^3}{E \times b}}$$

*d* = depth of beam (actual not milled)

*E* = Allowable modulus of elasticity (varies w/ species)

*b* = actual breadth of beam (1.5")

*w* = lbs of load per lineal foot

*L* = span of beam in feet

Equation 1 Span Depth Calculation

Incidentally, for some reason the engineers figure that with three evenly spaced supporting beams, the middle one carries 5/8 of the weight and each joist-end beam carries 3/16.

Table 4 Floor Joist Span-table for "Standard or Better" Douglas Fir material

<b>Joist Size, Span and Spacing Chart</b>		
<b>Size</b>	<b>Span</b>	<b>On Center Spacing</b>
<b>2 X 6</b>	<b>9' max</b>	<b>12" *</b>
<b>2 X 6</b>	<b>8 feet max</b>	<b>16" *</b>
-----		
<b>2 X 8</b>	<b>Up to 9'</b>	<b>24 inches</b>
<b>2 X 8</b>	<b>10'6" max</b>	<b>16"</b>
-----		
<b>2 X 10</b>	<b>Up to 11'6"</b>	<b>24 inches</b>
<b>2 X 10</b>	<b>13 feet max</b>	<b>16"</b>
-----		
<b>2 X 12</b>	<b>Up to 14'</b>	<b>24 inches</b>

Floor boards

Both ground level floors and storage loft floors must be made of sound flooring material to prevent injury. Leaves and debris build up during the

.....

off-season and become saturated with trapped rainwater, even in areas that have not flooded. This combination of moisture and decomposing material rots out exposed floor boards in just a couple of seasons.

Since it is not usually visible to the public, plywood is often used for repairs of storage loft floors, but unprotected plywood breaks down much faster than "one-by" ordinary pine or Douglas fir.

Table 5 Panel Span Calculations for plywood loft decking

Panel Span Rating	Plywood Thickness (Inch)	Maximum Floor Span	Nails
32/16	15/32, 5/8, 19/32, 1/2"	16"	use 8d galv
40/20	19/32, 1/2"	20"	8d galv
42/20	5/8, 3/4, 7/7"	20"	8d galv
48/24	3/4", 7/7"	24"	8d galv
	1 1/8"	48"	10d galv
1 1/8" groups 1 & 2			
	1 1/4"	48"	10d galv
1 1/4" groups 3 & 4			

Panel Span calculations

Panels shall display the panel span rating stamp for inspection.

Note: The second number on "panel span rating" stamp is the value for floors built under assumptions above.

- Sizes, materials, connections and construction methods
- Size, direction, and spacing of all floor framing members
- Size, direction, and spacing of all beams, headers, and posts

*Special Requirements for Storage Lofts, Ladders and Stairs*

- All structural members shall be securely fastened and inspected for sound condition yearly.
- As stated above: lofts can not be supported by "stud-frame" house-style construction unless you have agreed to remove the entire structure after the event.

Closures and Guardrails

- All storage loft entrances or exits shall have closure devices to restrict access and these must be kept closed at all times except when someone or stored items are passing through. Failure to keep a storage loft secured may result in losing the right to use the storage loft.

.....

- Repeated failure to secure the loft may result in loft dismantlement being required.
- Guardrails shall be a minimum of 42 inches high with no opening through which a sphere larger than 4 inch diameter could pass. They should be attached in a way that securely resists any piece breaking outward or pulling its fasteners under sudden thrust. This means that you should design railings that keep fastener loads in "shear" rather than in "tension", and you must rely on mechanical attachments in addition to the mechanical fasteners.

Ladders and stairs

Removable ladders are much preferred to stairs that are permanently attached. In fact, stairs will be approved **only** where they must be installed to comply with Lane County requirements for "grandfathered" storage lofts over 150 square feet in area. Ladders must be firmly attached during the Fair, but must be removed from the site or secured in the loft during the rest of the year.

Safety considerations for storage lofts

- Storage lofts are not to be accessed by the public and are only to be accessed by booth workers.
- All ladders and stairways accessing storage lofts must be located in areas not accessible to the public.

The following additional requirements for storage lofts have been attached to permits since the 1989 Fair:

- All storage loft areas shall be provided with a gate with a secure latch or a safety rope with a safety attachment at both ends.
- Guardrails shall be capable of withstanding a 20 pound per lineal foot horizontal load, with intermediate openings of less than 4 inches.
- A 2 1/4 inch diameter round guardrail will span 4 feet. Four to ten feet of span requires a 4 inch diameter guardrail. (Note: Span means distance between supports.)
- If guardrails are attached to the outside of the vertical post, a 1/2 inch through-bolt (not a lag-screw) is required - better design is to attach them to the inside of posts.
- Lofts with 150 square feet or more require a stairway built to the latest OCF Booth Construction and Maintenance Manual Standards.

.....



Note the excellent detail work on the steps of this ladder, patterned after commercial ladders.

The tie rods provide strength against spreading. Wedges could be added in the middle to support the steps.

Good design allows a lighter structure and adds years to its useful life.

### Freestanding Lofts.

New lofts must be located above an existing booth or part of a new booth -- no freestanding lofts are permitted.

## *BOOTH REPAIRS*

### Post Repairs



Sistering rotten support post. Note different approaches to through-bolting

.....

There is too much variability in soils and material conditions for OCF BOOTH CONSTRUCTION MAINTENANCE MANUAL to state that a typical 8 inch diameter un-peeled round pole of Douglas Fir will last "X" years or that a typical 8 inch redwood post will last "Y" years.

Repairs to existing Posts (rotted base)

The most common repair to existing booths with storage lofts is to have one or more rotten supporting poles or posts. Construction Crew finds the bad ones by poking them at ground level with an ordinary screwdriver. Bad posts receive a wrap of flagging tape and the defect is noted on a red tag attached to the front of the booth.

Because a post holding up a storage loft is most definitely structural, a "minor repair" construction permit is required.

There are two basic methods for fixing a bad pole -- replacement or cutoff /pier pad. Both require a floor plan drawing and before and after drawings. You can use the examples provided in this manual for your own drawings by adding your own dimensions and indicating the size and spacing of framing numbers.

In choosing the best method of repair, the following factors should be considered:

1. How complicated will it be to take the structure apart and/or support it temporarily to allow replacement of the entire post?
2. Is it possible to place the new post side-by-side with the rotted pole and tie it in solidly to all of the structural members previously supported by the old post?
3. How far up the old post does the rot extend?
4. If changing from a post in the ground to pier pad, how much added bracing will be needed?
5. If this post is rotten, how many more are rotten or will be soon?
6. Are other closely related parts of the booth also in need of repairs?
7. How much time is available before the Fair to get work done?

.....

Typical Drawings for a Post Repair

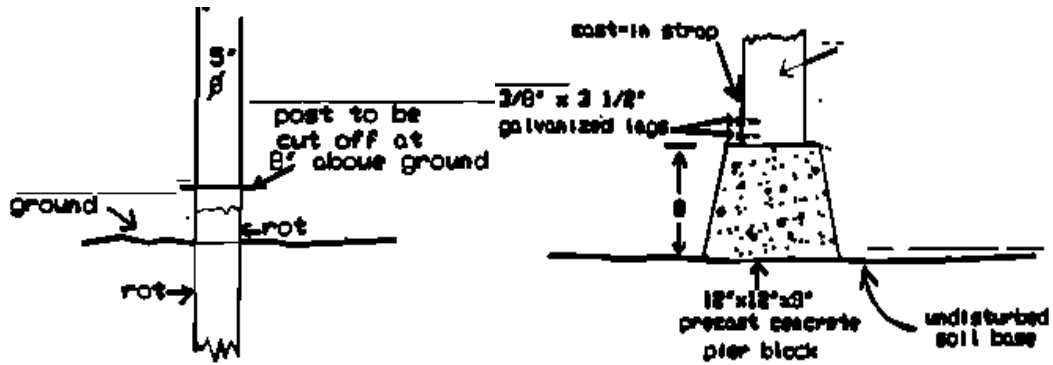
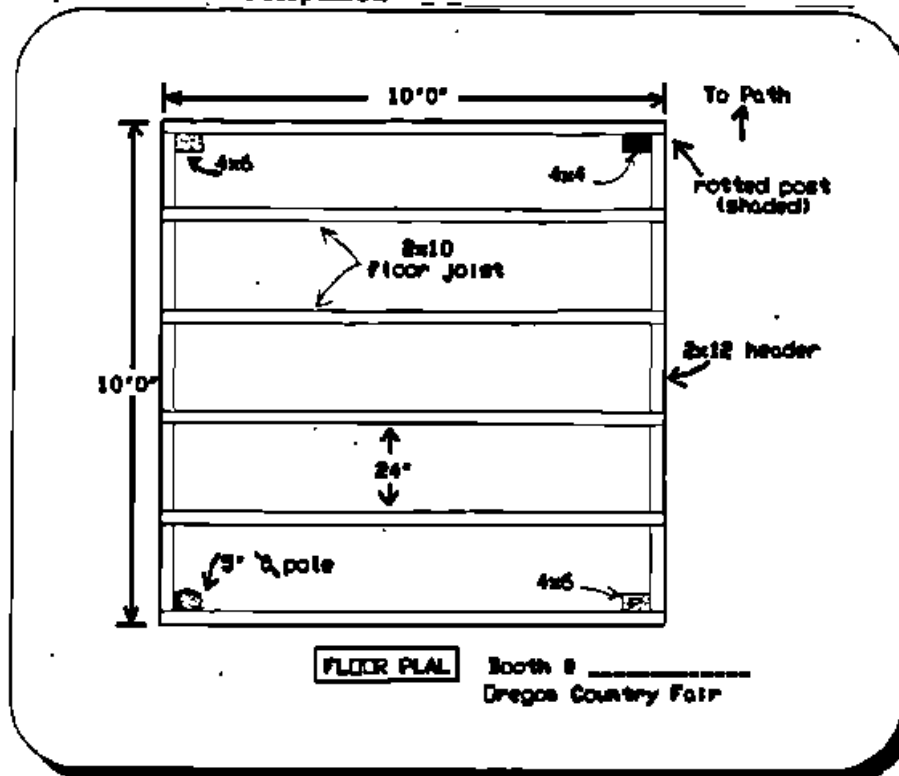

Figure 13 1 Post repairs - Drawing examples

Drawing for Location of Post to be Repaired



Post Work to Be Done—Typical Drawings

Figure 14 Example of typical drawings required for a post repair

Repairs to storage loft floors

The second most common repair to existing booths is "holey" floors. Leaves and other debris dam up mini lakes in storage lofts when it rains. Any flooring material will rot pretty quickly under those conditions and "waterproof" or exterior plywood also delaminates. If the Construction Inspection/Test Crew's hammer or mother nature's falling tree or limb



.....

broke through, you have several ways to repair a storage loft floor. This is also structural and requires a minor repairs permit.

Suggestion #1 Rotten Panel Replacement:

- 1. Remove and replace only the rotten floor pieces with identical pieces.
- 2. Remove and replace **all** suspect floor pieces with the same or different approved material. See the section on floor boards earlier in this manual for required material thickness depending on how far apart your floor joists are.
- 3. If most of the floor is sound you may still want to cover it over with plywood panels (to be taken home after the fair), to reduce loading on the weakened floorboards, insuring safety and preventing rotten material from breaking loose and falling.

Suggestion #2: Structural Plywood Overlay:

- A. Use only exterior grade plywood that is structurally sound. Thickness is still a function of span over load carrying framing members. 1/2 inch is a recommended minimum (see Flooring Design section).
- B. Remove any rotted, damaged or loose floorboards before overlaying the floor with plywood so they won't come loose, fall out and hurt someone below.
- C. Re-nail reusable old floorboards wherever loose.
- D. Cut the plywood to fit securely with no gaps and secure it in place with a few nails or screws.
- E. When the Fair is over, remove the fasteners, pry up the plywood, make sure the old floor will drain well, take the plywood home and reuse it next year.

Drawings and dimensions will be needed for the permit to be approved. A floor plan showing joist sizes and locations with the damaged floor areas shaded should do.

Repairs to beams or floor joists

Beams or floor joists supporting a storage loft floor sometimes rot or even get broken when falling tree parts strike them.

The necessary replacement sizes can be found in the Booth Design and Construction part of this manual.

These repairs provide you with a great opportunity to rebuild this part of the booth with increased portability in mind.

.....

.....

Suggested procedures:

1. Inspect the area surrounding the joist or beam for other signs of damage or deterioration that may need repair.
2. Measure and draw the framing/support system. Include every element of the structural design of the booth with sizes and dimensions.
3. Identify the part to be repaired or replaced by shading or coloring.
4. Briefly describe how the repair or replacement will be done.
5. You may want to consult with a construction coordinator on repair methods - you need to contact them for the permit application anyway.
6. Acceptable methods might include replacement with a piece of adequate size and grade, or placing the new piece alongside or underneath the old piece in cases where no end joints meet above the joist or beam.
7. Once you have an understanding with the construction coordinator about how the repair is going to be made, prepare and submit the permit application form (immediately below) with drawings and descriptions (if these parts are required) to one of the Construction Coordinators and, once repair is OK'd, proceed to fix it.

.....



Plan Drawings

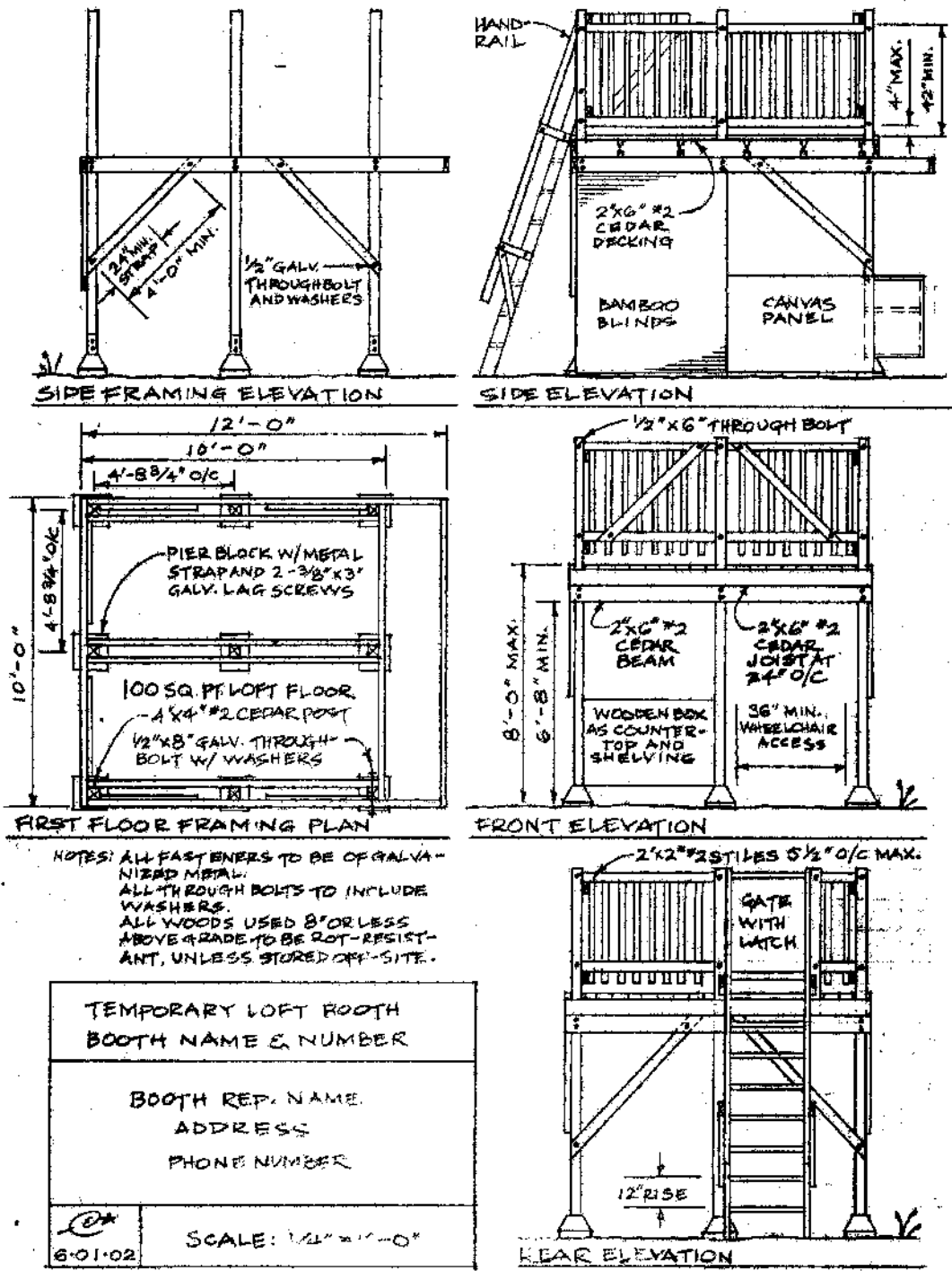

.....

*Required Information*

Almost all construction permit issuing agencies require a detailed series of drawings and list of specifications. A construction permit application would normally include a plot plan (location), foundation plan, framing plan, elevation (drawings of all sides), floor plans and many detail drawings. For the Oregon Country Fair, because booth structures are temporary, the requirements are far less stringent, but your plans MUST be readable. A checklist for plans follows:

- ❑ Name, address and telephone number of person who prepared plans
- ❑ OCF address by booth number with Booth Representative's name and phone number
- ❑ Approximate scale on all drawings in case any critical dimensions are omitted
- ❑ Size and height of all floors and temporary rain cover supports
- ❑ If repairing an existing booth, indicate additions or cover replacements by using different shading or colors for existing and new materials
- ❑ Floor plans and elevations that show at least 2 sides of the structure and indicate dimensions of structural components.
- ❑ If structural posts are set in ground, indicate the depth of holes, type of post material, and backfill material (dirt is now the preferred material)

Additional details that must be included in drawings or notes are:

1. Pier blocks and attachment method to posts (if applicable)
2. Diagonal bracing location, length and manner of attachment
3. Method of attachment of beams or header joists to posts
4. Joist size, spacing and method of attaching
5. Decking (floor) material and thickness
6. Safety rail construction and manner of attachment to resist outthrusts
7. Ladder location, attachment and relationship to loft
8. Closure (gate) mechanism or method at the ladder access opening in loft

Framing Plans MUST show:

1. Sizes, materials, connections and construction methods
2. Size, direction, and spacing of all floor framing members
3. Size, direction, and spacing of all beams, headers, and posts

Submitted by: \_\_\_\_\_ Date: \_\_\_\_\_

.....

.....  
**AFTER THE FAIR BOOTH MAINTENANCE CHECKLIST**

Booth  
Rep  
Check  
Below

OCF  
Inspector  
Check  
Below

*All required Post-Fair booth activities have been performed:*

- \_\_\_ All refrigerators left on the site have had their DOORS and latches REMOVED. \_\_\_\_\_
- \_\_\_ All refrigerators and other booth components left on site will be removed from the property before July 31<sup>st</sup> or a removal fee of \$25 per unit will be paid to OCF for each refrigerator remaining on the site on August 1<sup>st</sup>. \_\_\_\_\_
- \_\_\_ Ladder to storage loft has been removed and NAILED down or otherwise secured IN the loft to prevent floating away and to inhibit vandal access to site during off-season. \_\_\_\_\_
- \_\_\_ Stools, boxes or other "floatables" have been fastened securely in the storage loft and/or otherwise nailed or secured to the booth. \_\_\_\_\_
- \_\_\_ Straw and other ground covering material from this booth has been removed from site. \_\_\_\_\_
- \_\_\_ Booth has been cleared of anything that will trap leaves, debris and flood water. \_\_\_\_\_
- \_\_\_ Counter-skirts and other water-blocking water-catching structures have been removed. \_\_\_\_\_
- \_\_\_ All refrigerators and other booth components have been removed from the site. \_\_\_\_\_

*These recommended Post Fair activities have been performed:*

- Loft floor has been removed, stacked and secured. Inspection for soundness of structure has been performed, similar to the structural tests Coordinators and crew will be doing next Spring:
- All posts, studs, joists and floorboards have been re-checked for rot. Problems noted.
- All storage loft floorboards and any other floorboards checked for weaknesses. Problems noted.
- Final firm shaking given to structure to see if additional bracing is needed to withstand winter storms, blow-downs, flooding, etc..

**BOOTHS THAT FAIL TO PROPERLY "CLOSE-UP" MAY BE SUBJECT TO FEES OR OTHER ACTION**

Sign-off (for inclusion in this Booth's Construction File)	
Booth Number: _____	OCF Inspector: _____
Booth Rep: _____	
Date: _____	Date: _____

.....

## AFTERWORDS

This manual reflects years of learning compressed into a few bursts of activity.

It collects into one place and attempts to harmonize a great deal of information that has been scattered in other documents and collected in various minds over the years.

It is hoped that this organization is sufficiently clear that you were able to find what you needed and that what you found helped you figure out where to start asking questions, and what to ask about, in your quest to find the best way to do what you needed to do, or provided the answer to what you needed to know.

### *Your comments and suggestions are needed*

If you would like to see more detailed information in some areas, or could not find what you were looking for, or if you found contradictions, errors or omissions in the content of this manual, please let us know, so that we can fix them for next year.

### *Special Thanks*

Special thanks go out to the following people, without whose efforts it just would not have happened:

Jim Richmond, who created the original Booth Construction and Maintenance Manual years ago, and who wrote text and developed span tables and other technical information that survives into this revision of the manual.

Ed Criss who spent years building structures at the Fair and created the majority of the Example drawings that grace this book.

Jack Makarchek, who listened to Kirk and me, and outlined the history of the special relationship between The Fair and the Lane County building inspectors.

Steve Wisnovsky and the LUMP Crew, who got me a copy of the LUMP as soon as it was finished.

Andy Strickland, our OCF Caretaker, whose website is a wonderful place to see the place in wilder conditions than the rest of us can imagine, while still keeping your feet dry. Andy took some of the best photographs in this manual and wrote some of the observations.

Ande Grahn, an urban planner in the non-fair world, who actually read the draft of this document and made dozens of critically useful marks in red ink.

Kirk Shultz. Fearless Construction Coordinator who guided the development of this revision to the Booth Construction and Maintenance Manual and is now faced with putting it to use.

Norma Sax, OCF Office Manager who figured out how to print this thing off the web, and who proof-read and made dozens of extremely useful red marks on the first edition.

Joe Breskin Spring 2002

.....